

## Students' difficulties with tension in massless strings. Part II

S. Flores-García, A.E. Esparza, J.E. Chávez-Pierce, A.A. Hernández-Palacios,  
J. Luna-González, and J.F. Estrada-Saldaña  
*Universidad Autónoma de Ciudad Juárez,  
Avenida del Charro 450 Nte. Col. Partido Romero 32310 Ciudad Juárez Chih.*

M.D. González-Quezada  
*Instituto Tecnológico de Ciudad Juárez,  
Avenida Tecnológico 1340 Fracc. Crucero 32500 Ciudad Juárez Chih.*

Recibido el 27 de marzo de 2008; aceptado el 3 de abril de 2009

Muchos estudiantes de los cursos introductorios de mecánica presentan serias dificultades para comprender el concepto de fuerza como vector en el contexto de la tensión en cuerdas de masa despreciable. Una de las posibles causas es la falta de entendimiento funcional desarrollado durante las clases fundamentadas en una enseñanza tradicional. En este artículo presentamos una colección de este tipo de problemas de aprendizaje que tienen los alumnos pertenecientes a los cursos de física clásica y estática en la Universidad Estatal de Nuevo México, en la Universidad Estatal de Arizona y en la Universidad Autónoma de Ciudad Juárez. Estas dificultades de aprendizaje se obtuvieron durante una investigación conducida tanto en laboratorios como en el salón de clases. En esta segunda parte de la investigación se abordan problemas de entendimiento relacionados con el efecto del ángulo en la tensión y el argumento de “compensación”.

*Descriptores:* Tensión; fuerzas en cuerdas; dificultades de aprendizaje; fuerza como una tensión.

Many students enrolled in the introductory mechanics courses have learning difficulties related to the concept of force in the context of tension in massless strings. One of the potential causes could be a lack of functional understanding through a traditional instruction. In this article, we show a collection of this kind of students' difficulties at the New Mexico State University, at the Arizona State University, and at the Independent university of Ciudad Juarez in Mexico. These difficulties were collected during an investigation conducted not only in lab sessions but also in lecture sessions. In this second part of the investigation we show understanding difficulties related to the effect of the angle on tension and the “compensation arguments”

*Keywords:* Tension; forces in strings; learning difficulties; force as a tension.

PACS: 01.40.d; 01.40.Fk; 01.49.Ha

### 1. Introduction

In the first part of this investigation, we argued that for almost all students enrolled in an introductory physics course, the initial sequence of topics is kinematics, followed by dynamics. This first exposure to physics has Newton's second law –a vector equation– as its central theme. For this reason, students' perception of what physics *is*, and what it means to *do physics*, are strongly influenced by this topic.

Therefore, we claim again that in the ideal case, students will learn from this topic that fundamental principles of physics are powerful general ideas that have broad applicability. Too often, however, students fail to see the connections between the ideas that are presented. Rather than view physics as a subject grounded in a few far-reaching fundamental ideas, they instead gain an impression that the subject is a collection of context-specific [1] equations that must be memorized.

Most instructors of introductory physics courses recognize that thinking about physical quantities as vectors is difficult for students Flores and Kanim [2]. Even when instructors consistently model Newton's second law problem solutions by starting with free-body diagrams, many students avoid these diagrammatic tools. There is a tendency, even among fairly capable students, to jump to force components immedi-

ately, and to resort to memorizing what these components are in specific cases rather than deriving them from the geometry of the situation. Therefore, students have understanding difficulties with problems that require several steps along the solution process. These problems are called “multiple-step” problems.

In the process of an investigation conducted by Flores [3] into student use of vectors, he observed several difficulties with vectors. This observation motivated an investigation into student understanding of tension. In this article, we describe our observations into students' difficulties with tension. Therefore, the questions we hoped to answer with our investigation are: (1) Do students recognize the vector nature of tension force?; (2) Do students recognize that the tension in a massless string does not depend on the angle when this string is wrapped around a pulley?; 3) Do students recognize that the greater the angle with respect to the vertical, the smaller the tension for a three-string hanging system?; and 4) Do student use compensations arguments to find the magnitudes of the tensions in massless strings?

### 2. Previous research

As shown in the results from the *gymnast question* asked by Flores and Kanim [2], it is often the case that students do

not acquire a sufficient understanding of tension as a vector concept. Most students (70%) concluded that the tension in the left rope is one-half of the weight of the gymnast. Most of them gave the reasoning that the tensions in the ropes are equal to each other because the angles of the ropes are the same. Implicit in this response is an assumption that the scalar sum of the two tensions equals the weight. This response neglects the vector nature of tension. In order to make sense of forces, students need knowledge of the behavior of specific forces and the rules or assumptions used in physics to solve problems involving these kinds of forces.

On other questions they noticed that students were unable to identify essential features that determine tension. In this sense, we decided to conduct an investigation into student understanding of Newton's second law in the context of tension forces along a "massless" string.

To identify common student conceptual errors to recognize the existence of passive forces such as the tension in a string, Sjöberg and Lie [4] of the University of Oslo administered a written questionnaire to over 1000 secondary school students, future teachers, university students and physics graduate students.

Figure 1 shows two pendulums, one stationary and one swinging through its equilibrium position. Sjöberg and Lie asked students to indicate the forces acting on both pendulums. Results indicated that about 50% of the secondary-school students with one year of physics omitted the tension in the string. About 40% of the future teachers and about 10% of the graduate students omitted this force as well. A great number of students included a force in the direction of the motion of the swinging pendulum.

As part of an investigation into students understanding of gravity, Gunstone and White [5] asked 463 students to compare the weight of a bucket with the weight of a block when they are hanging from a string stretched around a pulley as shown in Fig 2. About one-half of the students concluded correctly that the weights are equal. About one-fourth stated that the block is heavier. The most common reason for this response was that "the block is nearer to the floor." There was a version of other reasons given. For example, "In the string used to link both the bucket and the block together over the pulley, tension exists in both its ends. At the end towards the bucket, the tension is less than at the end towards the block. This then causes the block to pull itself down thereby raising the bucket."

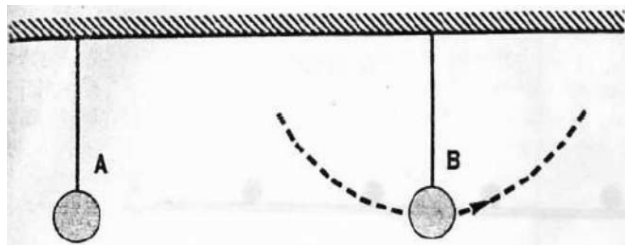

FIGURE 1. Experiment set used by Sjöberg and Lie to probe student difficulties with forces.

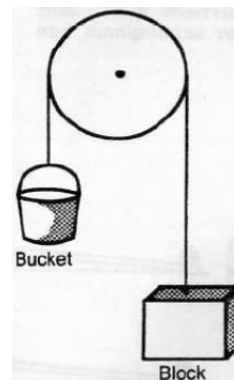

FIGURE 2. Experiment set used by Gunstone and White. The bucket and the block are suspended from a bicycle wheel.

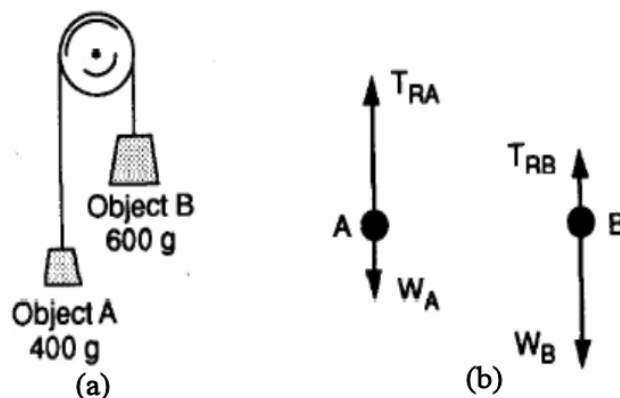

FIGURE 3. Physical system used by McDermott, Shaffer and Somers. a) Original Atwood's machine. b) Typical incorrect free-body diagram drawn by students to represent the forces exerted on blocks A and B.

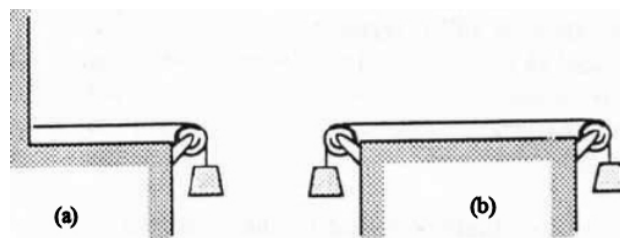

FIGURE 4. Physical situation used by McDermott, Shaffer and Somers. Students were asked to compare the tension in the two strings in cases (a) and (b).

Arons [6] made the observation that "massless strings are a source of significant conceptual trouble for many students." He also states that "students have no intelligible operational definition of *massless*; they fail to see why the forces of tension should have equal magnitude at either end; they proceed to memorize problem-solving procedures without understanding what they are doing."

This observation led to an investigation by McDermott, Shaffer and Somers [7] into some specific student difficulties with tension in the context of the Atwood's machine. Figure 3 shows a physical situation used in this investigation. The string and the pulley are massless. In interviews, most

students predicted that the heavier mass would fall and the lighter mass would rise. Although all recognized that the tension in the string acting on block A is greater than the mass of this block, on the free-body diagrams many showed different magnitudes for the tension exerted by the string on the two blocks.

As a part of the same investigation, a written question based on Fig. 4 was administered to students in three calculus-based courses. Students were asked to compare the magnitude of the tension at the middle of the strings in cases (a) and (b). Only about half of the students predicted that the two strings would have the same tension. Many students responded that the tension in the string attached to the two blocks would be twice that in the other string. Two common difficulties found were:

- 1) The belief that tension is the sum of the forces exerted at the two ends; and
- 2) The belief that an inanimate object, such as a wall, does not exert a force on a string.

McDermott, Shaffer and Somers concluded that student performance on simple qualitative questions that were asked after lecture instruction suggested that traditional instruction on the Atwood's machine did not improve understanding of dynamics. Practice in only one context such as the Atwood's machine is not enough to develop a functional understanding of the concept of tension.

### 3. Research techniques

The main objective of this investigation is the exploration of students' understanding difficulties with tension force. In this way, we can understand better the cognitive ideas student invoke when they try to solve tension problems. Once we know these operational and conceptual difficulties, we can start to design a new curriculum which impacts the cognitive development of these students.

Some physics understanding researchers have conducted this kind of investigation to explore, characterize and analyze conceptual understanding issues. For instance, McDermott and the Physics Education Group at the University of Washington has developed investigations where they explore students' cognitive problems and common sense beliefs related to physical concepts.

As in the first part of this investigation, there are two primary data sources that we use to assess student understanding and to learn about students' ideas about physics topics and about the prevalence of these ideas in a given student population. These are individual student responses to questions in one-on-one interviews and student responses to written questions. We describe each of these in turn.

#### Written questions

Our primary source of data for our investigation was student responses to written questions. These questions were asked

on homework (both laboratory and lecture), as laboratory pretests, and on classroom quizzes and examinations. Since we are primarily interested in students' conceptual understanding of physics, the questions we ask are primarily qualitative rather than quantitative. Student responses to these questions are typically analyzed and categorized on the basis of response and of the reasoning given for that response.

In our analysis of these written questions, we are looking for *patterns* of student responses, either correct or incorrect. These patterns may be patterns of incorrect ideas, a common tendency to focus on irrelevant features, patterns of reasoning, or patterns of procedure. Some features of common student responses that seem to lead to correct responses may then form the basis for curriculum exercises that reinforce productive lines of reasoning. Conversely, other patterns of responses may indicate that there is a need for curriculum that elicits a common misconception or error of procedure and reasoning and then addresses this difficulty.

Physics education researchers have found that certain formats of written tasks are useful at eliciting students' ideas and reasoning. For example, a *ranking task*, presents students with a number of physical situations, and they are asked to rank the magnitude of a physical quantity in the given situation. A *comparison task* is similar except that students are asked to compare only two situations, possibly before and after some physical change. Another task that is useful at eliciting student reasoning is the *conflicting contentions task*, in which students are presented with statements about a physical situation and asked whether they agree with any of them. In general, students are asked to explain the reasoning underlying their responses.

#### Interviews

Interviews were conducted at New Mexico State University and by colleagues at Arizona State University. These interviews were audio or videotaped, and the tapes and student written responses were later analyzed. At NMSU, we interviewed students from the introductory calculus-based mechanics courses intended for engineering majors. All of these students were volunteers. The interviews last about 30 minutes. We designed the interviews to probe students' conceptual reasoning. During the interview students were asked questions about selected topics and were encouraged to explain the reasoning behind their responses.

### 4. Context for research

While the data presented here were collected primarily at New Mexico State University (NMSU), we have collected additional data from the Arizona State University (ASU), and the Independent University of Juarez in Mexico (UACJ). In this investigation, student responses from UACJ have been translated from Spanish to English.

The courses used as information sources for this investigation were:

- NMSU: Physics 215 (Introductory calculus-based mechanics).
- NMSU: Physics 211 (Introductory algebra-based mechanics).
- NMSU: Physics 215 laboratory.
- NMSU: Physics 211 laboratory.
- Arizona State University: Physics 212 (Calculus-based mechanics).
- Independent University of Juarez: General Physics I (Calculus-based mechanics).

Physics 215 is primarily intended for engineering majors. Instruction in introductory calculus-based physics courses at New Mexico State University consists of three 50-minute lectures. The sequence of topics in lecture follows the sequence in most textbooks. There is no recitation section.

Physics 211, the algebra-based physics course, covers more topics than the calculus-based course, but at a less rigorous mathematical level. The majors of the students enrolled in Physics 211 are approximately: 30% Engineering Technology, 30% Biology, 10% Agriculture, 5% Education, and 20% Other/Undeclared.

There is an associated 1-credit laboratory, Physics 211L and Physics 215L, that is required for some majors. About one-half of the students enrolled in the lecture portion of the course also take the laboratory. The 3-hour laboratory is graded separately from the lecture. All of the laboratory sessions are taught by graduate students. In laboratory, students work in small groups on materials intended to strengthen connections between observed phenomena and mathematical formalism, to promote scientific reasoning skills, and to foster conceptual understanding. Instead of a laboratory report, students are assigned laboratory homework intended to reinforce and extend concepts underlying the laboratory. Students are encouraged to *predict*, *compare* or *rank* variables in physical situations. Most of the laboratory sessions for both the calculus-based and the algebra-based course were based on *Tutorials in Introductory Physics* [8].

## 5. Traditional and modified instructions

At the University of Juarez, at the Arizona State University and in some courses at NMSU the instruction is characterized as traditional. By traditional instruction, we mean instruction that is similar in emphasis and approach to that found in most introductory classrooms. That is, there is no particular emphasis placed on the topics under investigation in this dissertation, nor is there any modification to the instructional technique used. In addition, the use of numerical and textbook problems on homework and exams. An example of a textbook problem is shown in Fig. 5. In this problem, students are asked to calculate the coefficient of static friction between the ladder and the floor.

A person of mass 50 kg stands on a ladder of weight 1500 N that is about to slide. The ladder is uniform and the person is located on the center of mass of the ladder. There is no friction between the ladder and the wall. The length of the ladder is 2.5 meters. The angle between the ladder and the floor is  $60^\circ$ . Find the coefficient of static friction between the ladder and the floor.



FIGURE 5. Example of problem used in traditional instruction.

A block is at rest on a ramp. The angle that the ramp makes with the horizontal is *greater than*  $45^\circ$ . Rank, from greatest to least, the magnitudes of the forces acting on the block. Explain how you determined your answer.

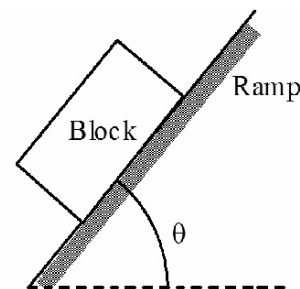

FIGURE 6. Example of question asked in a modified instruction.

Instruction in Physics 121 at Arizona State University all these courses have a 3-hour lecture and a 1-hour recitation section with traditional laboratories. About 90% of the students take laboratory sections. The laboratory is independent of lecture. Assessments in lecture include conceptual problems.

The questions we have asked at the University of Juarez were in a 3-hour calculus-based physics class. A 90-minute laboratory session per week is required. Laboratory is independent of lecture and mandatory. All laboratory sections are taught by the corresponding instructors of the groups. There is no recitation section. Most of the students are engineering majors. Questions on homeworks and examinations are primarily quantitative.

Most of the coursework at NMSU that we describe as modified was taught by Stephen Kanim. He modified the lecture the lecture section of the course to increase the emphasis on conceptual understanding. Many homework assignments, exams and exercises are composed of conceptual physical problems. The emphasis of the lectures was modified to focus on vector concepts: The course begins with an introduction of vector addition in the context of force, and velocity and acceleration are first introduced in two dimensions to emphasize their vector nature. An example of a problem used in modified instruction at NMSU is shown in Fig. 6. Students are asked to rank, from greatest to least, the magnitudes of the forces acting on the block. An explanation of the reasoning procedure is required. Some of the students draw a free-body diagram of the block and show a vector sum to compare the magnitudes of the forces.

In this article, we describe our identification of student difficulties with vectors and tension, and illustrate how this identification has guided some curriculum development. In

addition, this article provides details of our investigation of student difficulties with the vector nature of tension. We have separated these difficulties into categories: Ideas about compensation; and the belief that the magnitude of the tension depends on the angle of the string.

## 6. Students' learning difficulties with tension in massless strings

We have asked a number of questions on homework, pretests, and examinations in order to investigate student understanding of tension. Based on these questions we have classified students' difficulties with tension into five categories:

- 1) *Students' beliefs about the effect of the angle on tension.*
- 2) *"Compensation arguments" about tension.*

We describe these difficulties below.

### Students' beliefs about the effect of the angle on tension

**a.** The question shown in Fig. 7 was asked as part of a laboratory pretest. A correct answer is that the magnitude of the tension at point 2 is equal to the magnitude of the tension at point 3, and does not depend on the angle on the relative positions of the points along the string.

About one-half of 94 students in a calculus-based laboratory answered correctly. About one-fourth stated that the magnitude of the tension at point 2 was greater than at point 3 and one fourth said that it was less than the magnitude of the tension at point 3. About 20% of students used arguments about the difference between the angles that the string makes with the horizontal at points 2 and 3. Some examples of these responses are:

*"Tension at point 2 is less because has a greater angle at which the string is pulled."*

*"Tension at point 2 is less because the angle changes the tension."*

*"Tension at point 2 is less because the angle adds more tension."*

**b.** The question shown in Fig. 8 was part of the same laboratory pretest as the question shown in Fig. 7. A correct answer is that since there is no net force on the mass, the horizontal component of the tension in the two attached strings must be the same, and since the angle that string makes with the vertical is the same, the tensions at points 1 and 2 are equal. Since points 2 and 3 are on the same string they have the same tension, and therefore tensions at 1 and 3 are equal as well.

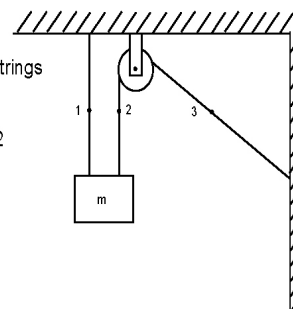

A block of mass  $M$  is hanging from two strings as shown in the figure.

Is the magnitude of the tension at point 2 greater than, less than or equal to the magnitude of the tension at point 3? Justify your answer.

FIGURE 7. Question to compare the magnitudes of the tension at two points on different sides of a massless and frictionless pulley.

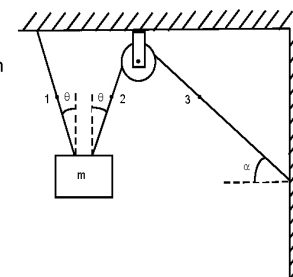

Now the two strings make an angle  $\theta$  with respect to a vertical line. If the angle  $\alpha > \theta$ , is the magnitude of the tension at point 1 greater than, less than, or equal to the magnitude of the tension at point 3? Explain your reasoning.

FIGURE 8. Pretest question to investigate student beliefs about effects of angle on tension.

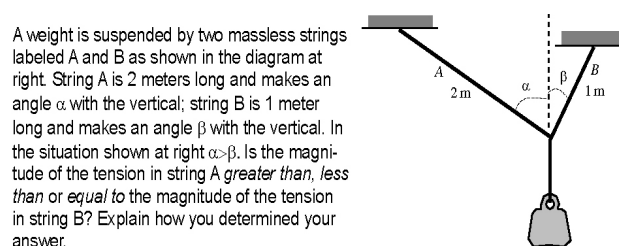

A weight is suspended by two massless strings labeled A and B as shown in the diagram at right. String A is 2 meters long and makes an angle  $\alpha$  with the vertical; string B is 1 meter long and makes an angle  $\beta$  with the vertical. In the situation shown at right  $\alpha > \beta$ . Is the magnitude of the tension in string A greater than, less than or equal to the magnitude of the tension in string B? Explain how you determined your answer.

FIGURE 9. Question about tension for three strings.

Although 40% of 94 students stated that the tensions were equal, only 6 students answered correctly with correct reasoning. About 35% did not include reasoning with their answer. About 30% said that the magnitude of the tension at point 1 is greater than the magnitude of the tension at point 3, and the same percentage of students concluded that tension at point 1 is less than tension at point 3. About 35% gave reasoning based on the angle  $\alpha$  being greater than the angle  $\theta$ . Some examples are:

*"Tension at point 1 is less than because greater angle more tension."*

*"Tension at point 1 is greater than because  $\theta$  is smaller than  $\alpha$  so greater tension."*

**c.** In a final exam at Arizona State University, 132 students from a calculus-based physics course were asked the question shown in Fig. 9. A correct answer is that the magnitude of the tension in string A is less than the magnitude of the tension in string B. Figure 10 shows a graphical method for adding tension A, tension B, and the weight. For the net

TABLE I. Results for tension and angle.

|                     | Juarez<br>Final Exam<br>Statics N=139 | NMSU<br>Final Laboratory Exam<br>Physics 215 N=111 |
|---------------------|---------------------------------------|--|
| Less than (Correct) | 71%                                   | 50%  |
| Greater than        | 5%                                    | 9%   |
| Equal to            | 15%                                   | 35%  |

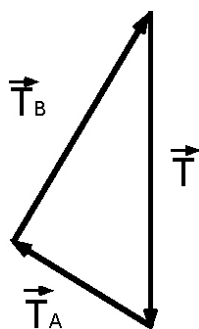

FIGURE 10. Expected reasoning procedure for the tension problem.

Two hanging masses are suspended as shown. In each case the pulley is massless and frictionless. The hanging mass in case B is two times the hanging mass in case A. The angle that the string makes with the horizontal is twice as large in case A as in case B. Is the magnitude of the tension in the string in case A *greater than, less than, or equal to* the magnitude of the tension in the string in case B? Explain your reasoning.

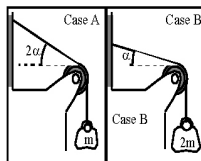

FIGURE 11. Translation of question asked in Juarez to identify beliefs about the effect of the angle on the tension.

force be zero, tension B must be greater than tension A because is opposite to a larger angle of the triangle.

Only 35% answered this question correctly. More than half stated that the tension in string A is *greater than* the tension in string B and about 10% believed that both tensions are equal. About a third of the students who answered that the tension in string A is greater than the tension in string B argued that it is because  $\alpha > \beta$ . Some of them stated that:

*“The tension in string A is greater than in string B. Since  $\alpha > \beta$  more of the weight is supported by string A, thus causing more tension in string A.”*

*“The tension of A is greater than B. A is suspended further away at a larger angle.”*

*“Greater, because it has a greater angle. Tension is simply  $mg$  for an object, but now considering an angle, it must be taken into account, so greater angle from  $90^\circ$ , greater tension.”*

Two common reasons were given for the answer that the tensions in both strings are equal: 1) The system is in equilibrium, and 2) the magnitudes of the tensions depend only on the hanging mass only. For example, one student said that *“The tension in string A is equal to the tension in string B because the weight is in equilibrium. The tension force does not depend on how long or short the string should be to produce more force or less force than the other string. Tensions depend on mass.”* Other student concluded that *“Since the weight is suspended, the net force is equal to zero. This means the tension force is equal in magnitude and opposite. In this case, the tensions are approximately equal.”*

d. In order to investigate students' beliefs about the effect of the angle of a massless string on the magnitude of its tension, 111 students from New Mexico State University and 139 students from the University of Juarez were asked to compare the magnitude of the tension in the massless string in cases A and B as shown in Fig. 11. The question was asked at the University of Juarez as part of a calculus-based course final examination. A multiple-choice version of this question was asked on a laboratory final examination for the calculus-based course at NMSU. A correct answer is that the tension in case A is less than the tension in case B because the hanging mass in case A is less than the hanging mass in case B. The angle that the upper portion of the string makes with the horizontal does not affect the magnitude of the tension.

As shown in table 1, about a half of the students from New Mexico State and about three fourths of the students from Juarez answered correctly. However, at the University of Juarez about one-half of 139 gave reasoning about the angles to compare the tensions. Fewer than 10% answered correctly without any reasoning.

Some of the students who concluded that the tension in case A is greater answered that the effect of the angle was more important than the effect of the mass on the tension: They argued that if the angle increases the tension increases as well. A translation of one of these responses is:

*“Although the mass B has greater weight than mass A, the angle of string B is less than A and this means there is not a lot of tension, since the greater the angle, the greater the tension.”*

Other students seemed to ignore the weight of the hanging mass completely. One example is shown below.

*“The string in case B is closer to the horizontal line and this exerts more force.”*

The explanations above are examples that directly relate the angle of the string with the tension. However, other students seem to believe that the more vertical the string, the greater the force acting. Some examples of this belief are shown below:

Both systems shown at right are at rest. Is the magnitude of the tension in the string in figure 1 *greater than, less than, or equal to* the magnitude of the tension in the string in figure 2? Explain.

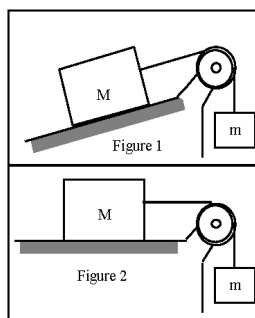

FIGURE 12. Question comparing tension when angle changes.

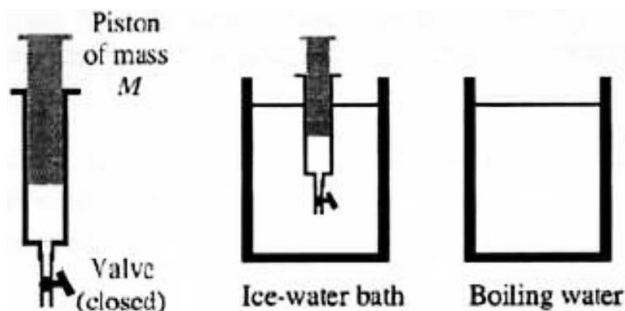

FIGURE 13. The vertical syringe question asked by Kautz, Heron, Loverude, and McDermott.

*“The tension in case A is greater because of the height of the string.”*

*“Greater than because tension is being released at the larger angle and height.”*

*“Greater than because the pulley in case B is at an angle closer to  $90^\circ$ .”*

e. As part of a pretest for the *Forces in Equilibrium* laboratory, 48 students from a calculus-based physics course at New Mexico State were asked the question shown in Fig. 12. In this case the magnitudes of the tensions in both strings are simply equal to the weight of the hanging mass. The angles of the ramps do not affect the magnitudes of the tensions because both systems are at rest.

Only 30% of the students answered correctly. Almost all the incorrect answers were that the tension in Fig. 1 is greater. Slightly fewer than one-half (21 students) gave reasoning based on the angle of the ramp: Of these students, five answered correctly, and fifteen answered that the tension in Fig. 1 was greater. Most of the students who answered that the tension in Fig. 1 was greater and reasoned based on the angle of the ramp just said that the angle of the ramp caused the tension to increase. Other students gave reasoning about the effect of the weight of the block on the ramp: *“The magnitude of the tension is greater because the force of gravity causes the block to move down the incline.”*

Explanations based on the weights of both blocks were also common for students answering that the tension is greater in Fig. 1:

*“Greater than because the string must now support part of the weight of the big block as well.”*

*“The tension in Fig. 1 is greater because in Fig. 2 the tension has to deal with the mass and the gravity.”*

*In Fig. 1, the tension is the mass  $m$  and gravity and the incline of  $M$  along the string.”*

This reasoning is similar to the reasoning described by McDermott and Shaffer [6] in response to the question shown in Fig. 4.

#### f. Commentary on students’ conceptual difficulties with the beliefs about the effect of the angle on tension.

Conceptual difficulties about the effect of angle on the tension of a massless string were found in two contexts: Questions about the tension in a system of three massless strings in two dimensions and questions about the tension in a massless string wrapped around a frictionless pulley. In both contexts, roughly one-half of students based their answers on the directions of the strings.

Most students seem to recognize that the magnitude of tension in strings depends on angle in static situations involving the strings. However, some of these students do not seem to recognize that the magnitude of tension does not depend on the orientation of the string when the string changes direction around a pulley.

The most common difficulty on the three-string questions was a belief that the string with the greater angle with the vertical has the greater tension. The most common difficulty in the pulley questions was that the tension in the string increases when the angle that the string makes with the vertical increases. Many of the students who gave this answer gave reasoning based on the increment of the y-component of the tension force. They seemed to believe that the greater the angle, the greater the tension. A similar difficulty was found for the ramp question in Sec. e (see Fig. 12) when the angle of the ramp was modified.

Most students did not use free-body diagrams to answer these questions. Most of the responses given seem to be application or misapplication of various “rules of thumb” about the effect of angle on tension rather than application of general physics principles.

Only a few students from Arizona State, New Mexico State and the University of Juarez used a graphical procedure to respond to questions about tension force in three connected strings. The use of a vector sum the technique was almost absent in our responses.

#### 2. “Compensation arguments” about tension.

It has been observed that, when asked to compare three related quantities, students often incorrectly employ arguments of the form “If quantity A increases and quantity B decreases, then quantity C remains the same.” These arguments are

known as 'Compensation arguments.' For example, O'Brien Pride, Vokos and McDermott [9] analyzed comparison tasks from 1000 students in Ref 11 regular and honors sections of the calculus-based physics course. Students were asked about the change in momentum of two objects of different mass if the same force is applied to them over the same distance. Many students reasoned that the change in momentum of the two objects must be the same. Some of these students claimed that "the momenta were equal because the greater velocity of the lighter puck compensated for the smaller mass." Similarly, students' compensation arguments about the ideal gas law  $PV = nRT$  were found by Kautz, Heron, Loverude and McDermott [10]. In interviews at the University of Washington, students were asked to compare the pressures and volumes of the gas contained in the vertical syringe shown in Fig. 13 in the initial and final states. Many students used compensation arguments: "The pressure remains the same because temperature decreases and volume increases."

We have noticed that students often use compensation arguments to reason about tension on some of the questions that we have asked. We give some examples of various forms of compensation arguments.

#### a. Tension compensation: Length and angle.

For the question in Fig. 13 (see *Students' difficulties with tension in massless strings Part I*), about 10% of students stated that the magnitudes of the tension in both strings A and B are equal because string A is longer but with a smaller angle:

*"Tension in string A is equal to the tension in string B. If A and B had been equal in length, but the angles remained, then there would have been a greater tension in string B, since  $\beta > \alpha$ . Therefore, because A is longer than B the tension in A is greater than if it had been the same length as B, and the tensions become equal."*

Of the students who were asked the question shown on in Fig. 17 (see *Students' difficulties with tension in massless strings Part I*), fifteen percent answered that both magnitudes are equal. About 10% indicated that the magnitudes are equal because the right string is twice the length of the left, and the inverse ratio for the angles compensates for the length. Although the question statement does not contain the actual ratio of the magnitudes of the angles  $\theta$  and  $\gamma$ , one student answered "Equal to because the length of the left string is the half of the length of the right string and the angle  $\gamma$  is half of the angle  $\theta$  therefore the magnitude of the tension in both strings is the same."

#### b. Tension compensation: Mass and angle.

For the question shown in Fig. 11, most students who answered that the magnitudes of both tensions are equal gave reasoning similar to "different angles compensate for different weights." One such explanation is shown below.

*"Tensions are equal because the weight is distributed in the same way as the different angles of the strings in both cases."*

#### c. Tension compensation: Orientation and weight

For the question shown in Fig. 11, some students gave compensation arguments related to the position of the strings with respect to the horizontal line. They argued that the tensions are equal because the string closer to the horizontal line exerts less force on the string. Two examples are shown below.

*"Tensions are equal in both cases because the mass in case B is greater but the string is closer to the horizontal, and this exerts less force."*

*"Although the weight in case B is greater, the position is different because in case A the string is further and in case B closer. It means that the tension is the same in both cases."*

The examples given in this section seem to have less to do with student beliefs about tension as with spontaneous reasoning about three or more quantities. Included in their discussion of compensation arguments, Kautz, Heron, Loverude and McDermott [10] have noted that students gave incorrect responses related to the interdependence of three variables. In making predictions, "many students focus on a single relation between two quantities that is valid only if the others are constant." In the examples shown in this section, some students assumed that the tension is constant in both strings, because there is an inverse proportionality between two variables such as the angles and lengths of the strings.

## 7. Implications for instruction

We have designed conceptual labs, pretest, posttest and homeworks as a didactic basis to develop a curriculum that impacts in the functional students' understanding of tension force. The theoretical explanation of this curriculum design is shown in Part I of this investigation. Therefore, we only show a complete lab in the appendix. In this lab, we have added the use of a *force table* in order students develop and invoke ideas about the dependency of tension on the angle of the strings on a plane. In the same way, we hope students understand how to add forces by using geometrical methods.

## 8. Summary

In interviews and on responses to written questions, we have observed that most students do not treat tension forces as vectors when attempting to answer qualitative questions. They rarely draw free-body diagrams, and even less often add forces to reason about relative magnitudes. Instead, they rely on learned or generated ad hoc rules about the effects of various physical features (angle with the horizontal or vertical



line, or compensation arguments) on the tensions. We have categorized these rules and given examples of each category based on a subset of the questions that we have asked. In addition, results show that many students use *compensation arguments* not only on the tension context, but also in other contexts of physics. It seems that this cognitive approach is developed by a students' system of common sense beliefs.

These observations seem to show that students do not develop a significant understanding of tension as a vector despite instructional efforts. In addition, they do not develop a functional understanding of tension despite a conceptual emphasis in instruction. One of the possible reasons of this lack of conceptual understanding could be the poor ability to emigrate among different mathematical representations of the knowledge object [11].

In a future investigation, we describe modifications to the laboratory in order to address student difficulties with forces primarily in the context of tension. Moreover, we will try to generate conceptual understanding by using computational simulations of physical situations.

## Appendix

### Addition of Forces laboratory

Lab 5: Addition of Forces

Name \_\_\_\_\_

## 1. Introduction

In this laboratory we look at forces in equilibrium. Newton's second law states that the net force acting on a body is equal to its mass times its acceleration:  $\Sigma \vec{F} = m\vec{a}$ . A complete understanding of Newton's second law requires that you be able to find the net force. Forces add as vectors, and in this lab we will practice adding forces. We will make inferences about the directions and magnitudes of individual forces in the special case where the net force acting on an object is zero.

When an object is moving at a constant speed and in a constant direction, the acceleration of that object is zero. In this case, we can make an inference from Newton's second law that the net force acting on that object is zero. That is, *if we add all of the individual forces acting on that object as vectors the resultant must be zero*. Since an object at rest can be considered to be moving at a constant speed (zero!) Newton's second law requires that if we add all of the forces acting on an object that is at rest, the resultant will be zero.

### 1.1 Lab Objectives

After completing this lab and the associated homework, you should be able to:

1. Add vectors together to determine the resultant.
2. Determine the magnitude and direction of the resultant.

3. Draw a vector sum based on the forces in a free-body diagram.
4. Make inferences about the magnitudes and directions of unknown forces in cases where the net force acting is zero.

## 1.2 Outline of Laboratory

Approximate sequence of the lab and homework:

1. Practice adding vectors to find the resultant.
2. Practice adding the forces from a free-body diagram.
3. Make inferences about the magnitudes of forces based on a vector sum.
4. Predict the relative magnitudes of tensions for three forces acting on a ring.
5. Use a force probe to determine the third force for an object at rest.
6. Use addition of forces to predict an unknown force.

## 2. Adding vectors

We begin this lab by considering vector addition without worrying about what those vectors represent.

### 2.1

Recall that vectors have both a magnitude (size) and a direction. When we add or subtract vectors, it is important that we do not change the vectors we are adding – that is, we do not want to change the magnitude or direction of the vector we are adding. When you add vectors together graphically, it is a good idea to add them in a different location. To add the vectors  $\vec{A}$ ,  $\vec{B}$ , and  $\vec{C}$  together, we start by redrawing vector  $\vec{A}$  in a new location. We then redraw vector  $\vec{B}$  with its tail placed at the position of the head of vector  $\vec{A}$ . In the same way, the tail of vector  $\vec{C}$  is placed at the head of vector  $\vec{B}$ . The vector obtained when you add two or more vectors together is called the *resultant*. The resultant vector from the addition of the three vectors above is the vector whose tail is at the position of the tail of the first vector (in this case, vector  $\vec{A}$ ) and whose head is at the position of the last vector (in this case, vector  $\vec{C}$ ). The resultant is labeled  $\vec{R}$  in the drawing below.

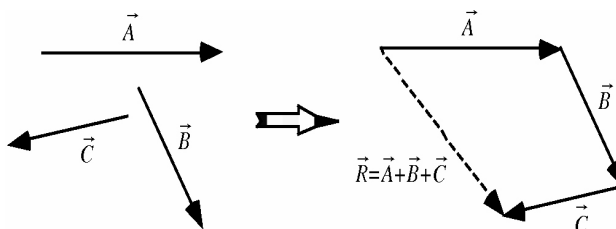

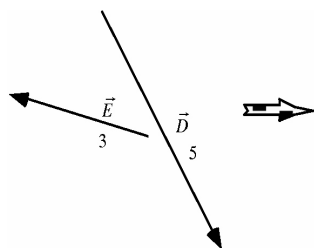

## 2.1.1

Show the sum of vectors  $\vec{D}$  (a vector of magnitude 5) and  $\vec{E}$  (a vector of magnitude 3) below.

## 2.1.2

Three students discussing this vector sum make the following contentions:

Student 1: "Once we find the resultant vector we can measure it to determine the magnitude of the resultant. That's why we have to draw the vectors to scale."

Student 2: "We don't have to do that. Since we are adding a vector of magnitude 3 to a vector of magnitude 5, the vector sum will have a magnitude 8."

Student 3: "No, that won't work because they are not scalars. The resultant will be one side of a triangle, and we need to use the Pythagorean theorem to find the magnitude of the sum. I calculate a sum of magnitude 5.83."

With which (if any) of these students do you agree? Explain.

## 2.1.3

Show the vector  $\vec{F}$  that satisfies the equation  $\vec{D} + \vec{E} + \vec{F} = 0$ . What is the relationship between this vector and the resultant in Sec. 2.1.1?

## 2.2

Use vectors  $\vec{G}$ ,  $\vec{H}$ , and  $\vec{I}$  at right to show that vector addition is commutative (*i.e.*, show that you get the same resultant no matter what order you add the vectors in).

## 2.2.1

Show how it is possible for two vectors to add to zero.

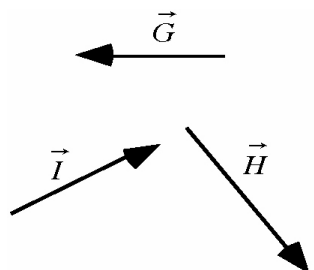

## 2.2.2

Show how it is possible for three vectors *all of the same magnitude* to add to zero. What is the angle between any two of these vectors? (Recall that the angle between two vectors is found by placing them *tail-to-tail*.)

Have your lab instructor check your answers to the questions above before proceeding.

## 3. Adding forces

In the previous lab you practiced drawing free-body diagrams. Here we add the forces that act on a body as represented by the free-body diagram to find the resultant, called the *net force*. Newton's second law relates the net force acting on a body to the acceleration of that body. In this lab we investigate the special case of zero acceleration, and therefore zero net force. An object has zero acceleration if it is at rest or if it is moving at a constant speed and is not changing direction.

## 3.1

Consider a suitcase sliding at a constant speed down a ramp that makes an angle of  $45^\circ$  with the horizontal. From the drawing and description, we can draw a free-body diagram:

We know that the weight points towards the center of the earth, the normal force is perpendicular to the ramp, and the friction force is parallel to the ramp opposite to the direction of motion.

We add the forces on the free-body diagram in the same way that we added the vectors in the previous section, except that in this case we don't know the lengths of these vectors (*i.e.*, we don't know the magnitudes of the forces). However, *we know that the vector sum must be zero* since the suitcase is not accelerating. Based on this, we can construct a vector sum:

The three vectors in the vector sum form a triangle, and we can use this triangle to reason about the relative sizes of the individual forces.

In this case, suppose the mass of the suitcase is 20 kg.

## 3.1.1

What is the magnitude of the weight?

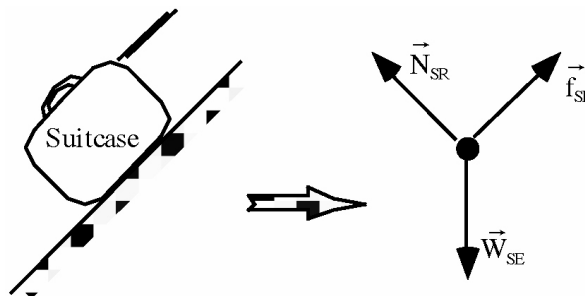

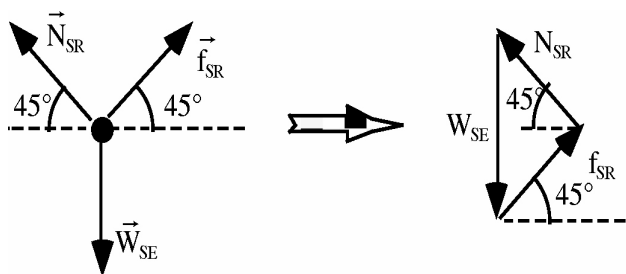
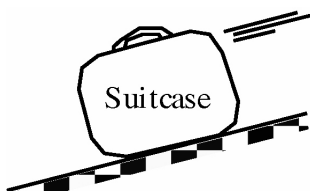

FIGURE 18.



3.1.2

What is the magnitude of the normal force? Explain how you determined your answer.

3.1.3

What is the magnitude of the friction force? Explain how you determined your answer.

8.0.1. 3.1.4

What is the coefficient of kinetic friction? Explain how you determined your answer.

Suppose that the ramp from section 3.1 was at an angle that was *less than*  $45^\circ$ , and that a different suitcase was sliding at a constant speed.

3.2.1

Draw a free-body diagram for this situation, and from this free-body diagram construct a vector sum.

3.2.2

Rank the magnitudes of the forces in your free-body diagram. Explain how you used the vector sum to determine your answer.

3.3.1

A mass is suspended from two strings as shown. Draw a free-body diagram, and then use the free-body diagram to construct a vector sum.

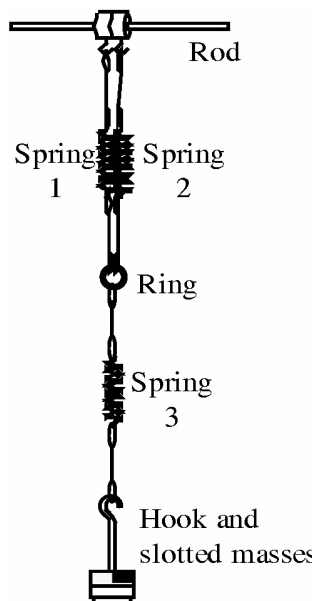
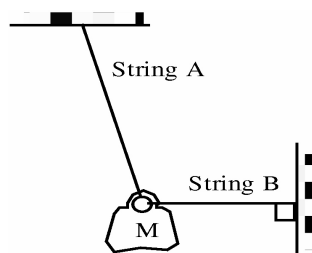

3.3.2

Rank the magnitudes of the forces in your free-body diagram. Explain how you used the vector sum to determine your answer.

3.3.3

If the mass  $M$  is 300 grams, use your vector sum to find the *approximate* value of the tensions in strings A and B.

Have your lab instructor check your answers to the questions above before proceeding.

**4. Adding force vectors**

**4.1**

For the situation shown at right, draw a free-body diagram for the ring. (You can ignore the weight of the ring.) What is the net force on the ring? Explain how you can tell.

**4.2**

Show a vector sum of the forces on your free-body diagram. Based on this vector sum, predict the relative lengths of the three springs. Explain how you determined your prediction.

Test your prediction using about 400 grams of mass on the hook (450 grams total), and resolve any inconsistencies. Measure the lengths of the 3 springs in this case, and record them here.

#### 4.3

Again draw a free-body diagram for the situation shown at right. Again show a vector sum of the forces on your free-body diagram. (When you draw this vector sum, be careful that you do not change the direction of any of the vectors!)

#### 4.4

Based on this vector sum, predict the relative lengths of the three springs. Explain how you determined your prediction.

Would you expect the length of spring 1 in this case to be *greater than*, *less than*, or *equal to* the length of spring 1 in the situation shown in exercise 4.1 above? Explain your reasoning.

Move the suspension hooks outward so that when about 450 grams total is suspended, the angle between the upper strings is  $60^\circ$  as shown. Measure the lengths of the 3 springs and record them here. Were your answers above correct?

#### 4.5

Now draw a free-body diagram for the case where the angle between the upper strings is  $120^\circ$ . Predict the relative lengths of the three springs. Use a drawing of the vector sum of the forces on the ring to explain the basis for your prediction. (Hint: What kind of triangle is formed by the vectors of the vector sum you have drawn?)

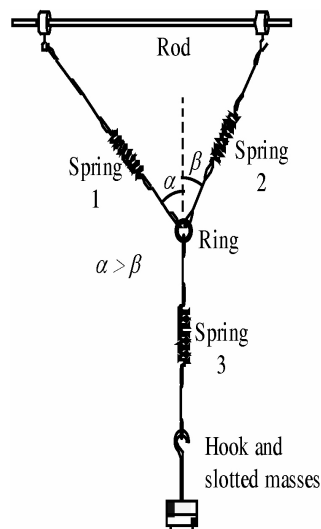
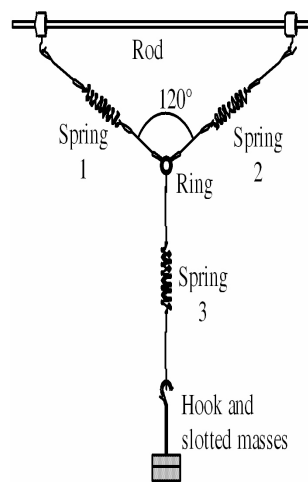
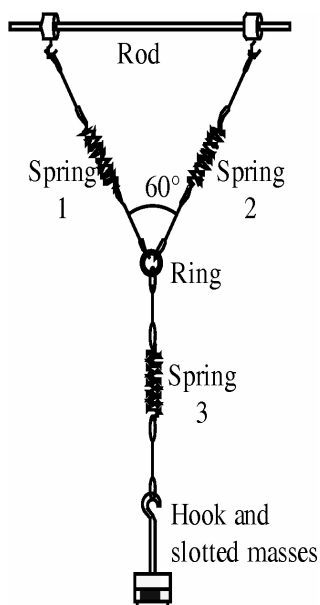

Move the suspension hooks outward so that with 250 grams total suspended, the angle between the upper strings is  $120^\circ$  as shown. Measure the lengths of the 3 springs and record them here. Were your answers above correct?

#### 4.6

For the situation shown at right, the angle  $\alpha$  is greater than the angle  $\beta$ . Predict the relative lengths of the springs. Explain the basis for your predictions.

#### 4.7

Test your prediction, and resolve any inconsistencies. Then discuss your answers above with your laboratory instructor before continuing.

## 5. Addition of scaled vectors

### 5.1

We will now use a force table to observe the forces acting on a small ring. When the ring is not accelerating, it is said to be in equilibrium. (Later this semester we will add second condition to the motion of an object in equilibrium having to do with rotation.)

Place mass hangers on two of the strings that are attached to the ring. Hook the force probe to a third string. Add *different* masses (between 200g and 500g) to the two mass hangers.

Hold the force probe horizontally and re-zero it (with no mass attached). Then hold the force probe so that the ring is no longer touching the pin and the ring is centered on the force table.

Record the direction and magnitude of each horizontal force acting on the ring. In the space to the right, draw a free-body diagram of these forces on the ring.

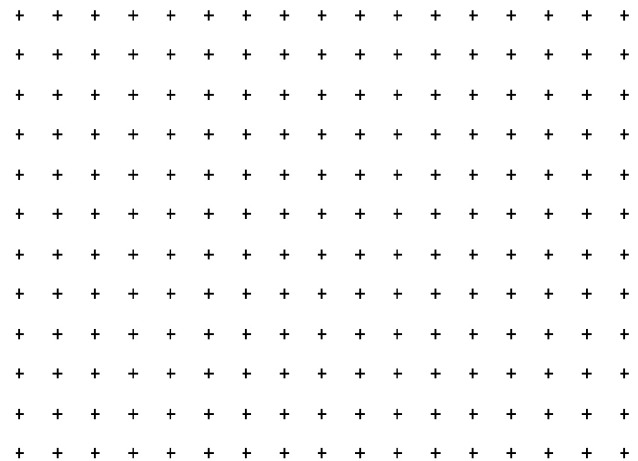
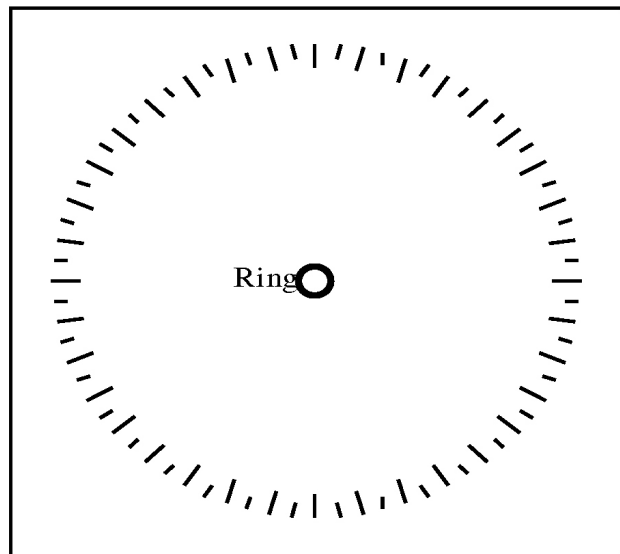
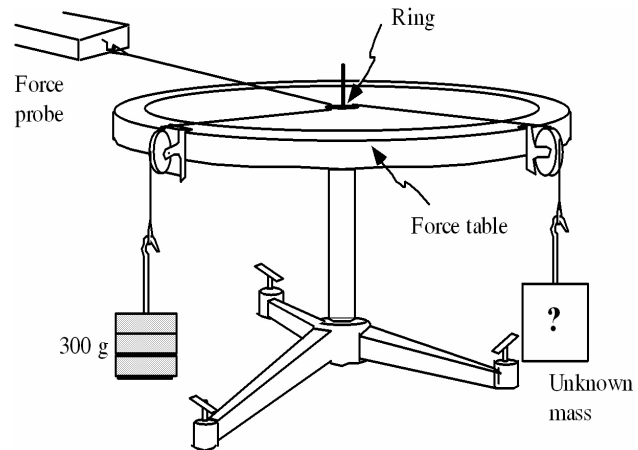
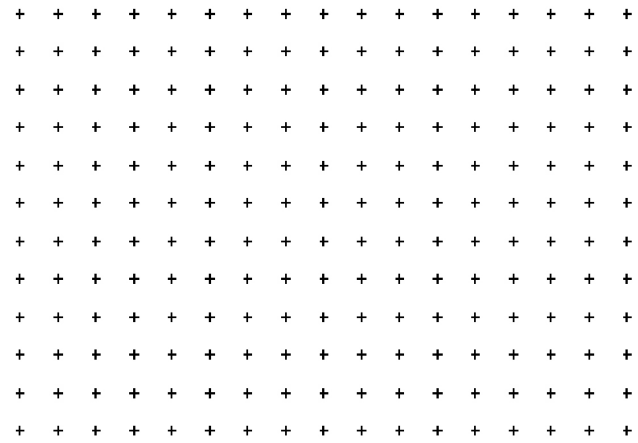
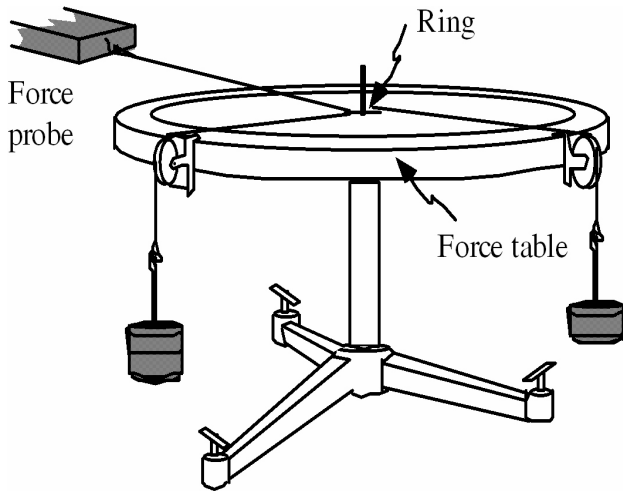

### 5.2

On the next page we will add the forces (as vectors) recorded above graphically and to scale. Choose a scale for the vectors that you will use to represent the forces on the ring (for example, 4 cm = 1N). Do not choose a scaling factor such that your vectors are too small to work with! (Note: For simplicity, you may approximate  $g \cong 10\text{m/s}^2$ .)

By constructing a scale drawing using a ruler and protractor, find the vector sum (or resultant) of the 3 tension forces on the ring by the tip-to-tail or polygon method. (That is, draw the tip of each vector at the tail of the succeeding vector.) The resultant vector is drawn from the tail of the first vector to the tip of the last vector.

What would you expect the magnitude of the resultant vector to be in this case?

Is the resultant vector that you actually obtained graphically consistent with what you expected?

### 5.3

Your instructor will give you an unknown mass. Hang this mass from one of the pulleys. Hang a 300 gram mass from a second pulley that is placed at an angle of between 110 and 150° from the pulley that has the unknown mass.

Use the force probe to find the magnitude of the tension in a third string attached to the ring, and the direction of this third force acting on the ring.

Use a scaled vector sum to determine the unknown mass.

Once you have made a prediction based on your scaled diagram, use the scale to measure your unknown mass.

Before you leave the lab, show your lab instructor your scaled vector sum.

- 
1. E. F. Redish, J.M. Saul, and R.N. Steinberg, *Am. J. Phys.* **66** (1998) 212.
  2. S. Flores, S. Kanim, and H. Kautz, *Am. J. Phys.* **72** (2004) 460.
  3. S. Flores, "Student use of vectors in mechanics", PhD. Dissertation, Department of Physics, New Mexico State University, 2006.
  4. S. Sjoberg and S. Lie, "Ideas about force and movement among Norwegian pupils and students", Report 81-11, The Centre for School Science, University of Oslo, Blindere, Oslo 3, Norway, 1981.
  5. R.F. Gunstone and R.T. White, *Sci. Educ.* **65** (1981) 291.
  6. A. Arons, *A guide to Introductory Physics Teaching* (Wiley, New York, 1990).
  7. L.C. McDermott, P.S. Shaffer, and M.D. Somers, *Am. J. Phys.* **62** (1994) 46.
  8. L.C. McDermott, P. Shaffer, and the Physics Education Group at the University of Washington, *Tutorials in Introductory Physics* (Prentice-Hall, New Jersey, 2002).
  9. T.O'Brien Pride, S. Vokos, and L.C. McDermott, *Am. J. of Phys.* **66** (1998) 147.
  10. C.H. Kautz, P.R.L. Heron, M.E. Loverude, and L.C. McDermott, *Am. J. of Phys.* **73** (2005) 1055.
  11. S. Flores *et al.*, *CULCYT* **5** (2008) 19.