

## Position sensing of a Gaussian beam with a power meter and a knife edge

RUFINO DÍAZ-URIBE, MARTHA ROSETE-AGUILAR AND ROBERTO ORTEGA-MARTÍNEZ

*Laboratorio de Optica Aplicada, Centro de Instrumentos  
Universidad Nacional Autónoma de México  
Apartado postal 70-186, 04510 México, D.F., México*

Recibido el 11 de enero de 1993; aceptado el 11 de febrero de 1993

**ABSTRACT.** A simple method for sensing the 1-D position of a Gaussian beam is proposed. The method makes use only of a commercial power meter and a knife edge avoiding then, the use of the so called position sensing detectors. By using the usual formulae for Gaussian beams we deduce the position of the beam in reference to the knife as a function of the measured power of the meter. The method is limited to measure deviations of the beam as large as the width of the beam; we show that the accuracy of the method depends on the relative position, as well as on the total power and the width of the beam. We show some experimental results.

**RESUMEN.** Se propone un método simple para medir la posición de un haz gaussiano en una dimensión. El método hace uso de sólo una navaja y un medidor comercial de potencia, y no requiere el uso de los conocidos detectores de posición. Se deduce una expresión para la posición del haz, relativa al borde de la navaja, como función de la potencia medida a partir de las fórmulas usuales para haces gaussianos. La limitación del método está en la imposibilidad de medir desviaciones del haz más grandes que el diámetro de éste. Se muestran algunos resultados experimentales y se discute la manera de extender el método a dos dimensiones.

PACS: 07.60.-j; 42.60.Jf; 42.80.-f

### 1. INTRODUCTION

Accurate measurements of the position of laser beams have become an important task for many applications. For example, we can mention all the methods for profiling optical surfaces by measuring the deviation of a reflected He-Ne laser beam [1]. In such methods, the location of the beam ranges from direct visual observations on a screen [2] to the use of specialized detectors such as the bicells [3], quadrants [4] or the lateral effect photodiodes [5]. Often, the visual techniques take advantage of the diffraction pattern produced by some aperture [6] or some obstacle [3, 7].

In the present paper an alternative method for measuring the position of a Gaussian beam as those produced by lasers working in the TEM<sub>∞</sub> mode. The basic idea consists of blocking out about a half of the beam with a knife edge, while the power of the transmitted beam is monitored by a detector. The power variations sensed by the detector are closely related to the movement of the beam at the knife edge plane.

## 2. BASIC THEORY

### 2.1. Relation between the measured power and the position

As is well known the irradiance pattern of a Gaussian beam is given by

$$I(x, y) = I_0 \exp \left[ -\frac{2(x^2 + y^2)}{r_0^2} \right], \quad (1)$$

where  $I_0$  is the maximum irradiance of the beam at its center of symmetry, and  $r_0$  is the radius of the beam measured at the point where the irradiance has a value of  $I_0/e^2$ .

Thus, when a part of the beam is blocked out by a knife edge parallel to the  $y$  axis, and located at a distance  $x$  from the center of the beam, the power incident on a detector behind the knife is given by

$$P(x) = \int_{-\infty}^{+\infty} \int_{-\infty}^x I(x', y) dx' dy, \quad (2)$$

where it is assumed that the opaque zone of the knife edge is on the semiplane  $x' > x$ .

It is easy to show that Eq. (2) becomes

$$P(x) = \frac{1}{2} P_T \left[ 1 + \operatorname{erf} \left( \frac{\sqrt{2} x}{r_0} \right) \right], \quad (3)$$

where  $P_T = \frac{\pi}{2} r_0^2 I_0$ , is the total power of the unblocked beam, and

$$\operatorname{erf}(t) = \frac{2}{\sqrt{\pi}} \int_0^t \exp(-t'^2) dt', \quad (4)$$

is the well known Gaussian error function.

Due to the fact that Eq. (3) gives a monotonous relation between the power,  $P(x)$ , measured by the detector and the position,  $x$ , of the knife edge, relative to the center of the beam, it is possible to revert unambiguously the relation and obtain the position of the edge as a function of  $P(x)$ . Solving Eq. (3) for  $x$ :

$$x = \frac{r_0}{\sqrt{2}} \operatorname{erf}^{-1} \left[ \frac{2P}{P_T} - 1 \right], \quad (5)$$

where  $\operatorname{erf}^{-1}$  means the inverse of the error function; this relation tells that for each transmitted power,  $P$ , a position of the knife edge is given. Eq. (5) is useful only when the knife is blocking out a part of the beam; otherwise,  $P = 0$  when the beam is completely blocked out, or  $P = P_T$  when the knife does not block out the beam at all, yielding a wrong result. It must be clear that for measuring  $x$ , it is necessary to know both, the radius of the beam,  $r_0$ , and its total power,  $P_T$ .



### 2.2. Linear approximation

It is not so easy to evaluate the inverse error function in a exact way. Apart from using a set of tabulated data, the error function, however, may be described as a power series of the argument, thus several approximations may be done for a numeric evaluation of Eq. (5).

In the experimental setup, for the case that the knife edge is either located at the center of the beam or very close to it, and when the beam moves a very small distance far from the initial point, it is possible to use the linear approximation, in such a case

$$x = \sqrt{\frac{\pi}{8}} r_0 \left[ \frac{2P}{P_T} - 1 \right]. \quad (6)$$

Such an approximation yields a sistematic error that can be evaluated; for example, if the measured power differs from a half of the total power less than 9.8% of  $P_T$ , the position evaluation by using the linear approximation does not differ from the exact calculation in more than 1% of the beam radius  $r_0$ .

A word of caution has to be said at this point. For a laser beam whose power variations are appreciable, one has to measure also  $P_T$  in order to correct Eq. (5) or (6) for this effect. For an intensity stabilized laser this effect may be neglected in some cases.

In any case, it is necessary to know the radius of the beam and its total power. The literature reports several methods for measuring the radius [8, 9, 10], these methods are not easy to use in a direct way. In what follows a very simple method is proposed.

### 2.3. A method to measure the beam radius $r_0$

The linear approximation given by Eq. (6), allows to determine the radius of the beam by measuring the slope of the curve in a plot of  $P$  vs  $x$ , when the knife edge located at the center of the beam. Calling  $m$  to the slope, the radius is given by

$$r_0 = \sqrt{\frac{2}{\pi}} \frac{P_T}{m}. \quad (7)$$

The total power, of course, is easily measured.

The experimental result can be compared with the value obtained by directly locating the  $I_0/e^2$  points in the plot  $P$  vs  $x$ , where the abscissas are given by the next values:

$$x_- = x(0.02275 P_T) \quad \text{and} \quad x_+ = x(0.97725 P_T), \quad (8)$$

where  $x(P)$  means the position of the knife edge at which the measured power has the  $P$  value.

#### 2.4. Error analysis

The error associated to this method is given by the derivative of the position with respect to the measured transmitted power; then, from relation given by Eq. (5), we find that

$$\delta x = \sqrt{\frac{\pi}{2}} \frac{r_0}{P_T} \exp\left[\frac{2x^2}{r_0^2}\right] \delta P = \frac{1}{I(x)} \delta P, \quad (9)$$

where

$$I(x) = \int_{-\infty}^{+\infty} I(x, y) dy = \sqrt{\frac{\pi}{2}} I_0 r_0 \exp\left[-\frac{2x^2}{r_0^2}\right], \quad (10)$$

is also a Gaussian expression. Then the method has less error when the knife edge is located at the center of the beam; in such a case

$$\delta x(x=0) = \sqrt{\frac{\pi}{2}} \frac{r_0}{P_T} \delta P. \quad (11)$$

Eq. (11) shows that the method is more sensitive for measuring the beam position for a powerful and for a narrower beam. However, this result limits the operation range, because the error significantly increases at the edge of the beam.

For example, the Spectra-Physics stabilized laser, model 117A, has a nominal beam radius  $r_0 = 0.25$  mm, a measured total power  $P_T = 1.7$  mW, and a nominal intensity stability of 1%. Assuming that is possible to measure the power of the beam with an accuracy of  $17 \mu\text{W}$ , then one can sense the position of such a laser beam with a sensitivity of about 3 micrometers in the very central part of the beam. If a positive lens is used to reduce the radius of the beam, for example to a tenth of its original value, then the sensitivity is increased to 0.3 micrometers. Of course the lower radius of the beam that is possible to get is limited by diffraction.

### 3. EXPERIMENTAL PROCEDURE

For testing the proposed method the experimental setup is very simple (see Fig. 1). It consist of a 1.7 mW stabilized Spectra Physics He-Ne laser Model 117A, a knife edge and a silicon photodiode. To secured them from unwanted movements and vibrations, the three elements were screwed on a breadboard. The support of the knife edge was screwed on a precision translation stage that was driven by an actuator of the Series 850A, and controlled by the PMC300 System, both from Newport. This arrangement gave fine movements and permitted to the knife edge to travel a distance enough to intercept all of the laser beam. The measurement of the power of the laser light was done



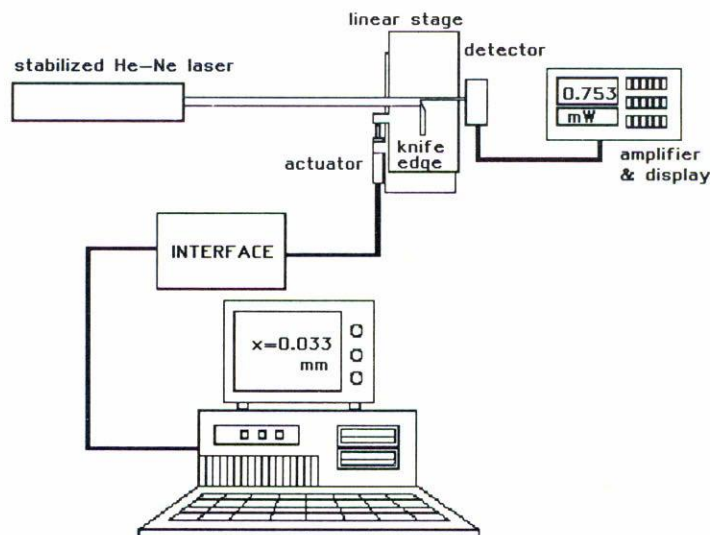

FIGURE 1. Experimental setup for testing the proposed procedure for sensing the laser beam position. Direct beam. The actuator data of the knife edge position are compared with the computed data using the linear approximation (Table I).

by a Newport Laser Picowatt Digital Power Meter Model 835 with a photodiode Model 835-UV.

In order to measure the beam radius, the next procedure is followed. First the knife edge is located just at the side of the laser beam, in this way the beam passes without interception and the total power is measured. Then the actuator is moved a short distance in order to start to blocking out the beam, the position of the actuator is read directly from the computer screen and the transmitted power is also recorded. This procedure is repeated until the laser is totally blocked out and the power meter reads less than a 1% of the total power. The distance moved by the actuator in each step is different in each case. For example, for the direct beam having a radius ranging 0.4 mm, each step is about 0.01 mm; while for a focused beam by a lens with a focal length of 10 mm, whose radius is reduced to a 0.03 mm, the steps are of 0.005 mm; in this case the step size is limited by the positioning system.

By using the recorded data as explained above, the slope of the curve is evaluated at a half of the maximum power value, then the radius of the beam on the knife edge plane is computed by using Eq. (7). In order to check the value of  $r_0$ , its value is also calculated by means of Eq. (8).

Inserting the  $r_0$  value in Eq. (6) the position of the knife edge referred to the center of the beam can be measured. In order to test the reliability of the measured position, the following experiment is conducted.

After  $r_0$  and  $m$  were measured, the knife edge was located at the center of the laser beam, and the laser power recorded. Then the knife edge was moved a short distance and the laser power recorded again; even the Laser Power Meter have a resolution of one thousandth of the signal, the beam power fluctuations allows only to have an accuracy of

TABLE I. Comparison of measured valued for the relative position of the laser and the knife edge. Direct beam.  $P_T = 1.528$  mW,  $r_0 = 0.435$  mm;  $\Delta x_{\text{meas}}$  data given by the actuator.

$N$	$\Delta P$ (mW)	$\Delta x_{\text{meas}}$ (mm)	$\Delta x_{\text{cal}}$ (mm)	$\delta(\Delta x)$ ( $\mu\text{m}$ )
1	0.025	-0.0093	-0.0089	-0.4
2	-0.027	0.0092	0.0096	-0.4
3	0.049	-0.0184	-0.0175	-0.9
4	-0.052	0.0185	0.0185	0.0
5	0.074	-0.0275	-0.0266	-0.9

one hundredth of it. The movements were done in the interval where the linear approximation was still valid. Table I accounts for the measurements done for this part of the experiment; in the last column the differences between the data given by the actuator displacements,  $\Delta x_{\text{meas}}$ , and the computed data values,  $\Delta x_{\text{cal}}$ , are listed. The maximum difference  $\delta(\Delta x)$  is less than 1  $\mu\text{m}$ . The variations of measured power are listed in the second column.

The next part of the test consisted in repeating the procedure, but with a focused laser beam by a positive lens with a focal distance of 10 mm (see Fig. 2). Clearly, here the movements were very small; the initial and final laser power beams were measured again. Now, a Hewlett-Packard interferometer, Model 5528A, was used so we could compare the measurements obtained with the proposed method and the ones obtained with the interferometer. Corresponding results of this last experiment are listed in Table II. This last test gave an approximation around one tenth of a micrometer. For an exact evaluation of the  $x$  values, Eq. (5) is used instead of the linear approximation given by Eq. (6). The case  $N = 1$  in Table II, improves to  $\Delta x_{\text{cal}} = 2.99$   $\mu\text{m}$ , reducing the difference with the interferometric result to  $\delta(\Delta x) = 0.02$   $\mu\text{m}$ .

For larger displacements full evaluation of the inverse of the error function has to be done. In such a case a look up table may be useful instead of a numeric computation.

Figure 3 shows the transmitted power,  $P$ , measured by the detector as a function of the knife edge position,  $x$ . Plot 1 is for the direct beam, whereas plot 2 is for the focused beam. The change in the beam radius is evident.

#### 4. ADDITIONAL COMMENTS

In the above described experiments the knife edge movements were sensed indeed, while the laser beam was always in a fixed position. This, however, showed the feasibility of sensing very fine relative displacements between the beam and the knife edge. Thus for sensing the beam position, it is necessary to secure the knife edge and the transmitted power variations yields the beam position.

It is easy to see that for sensing the 2-D position of a beam, it can be divided by a beamsplitter into two beams and sense each one by using two knife edges in  $x$  and  $y$  directions.



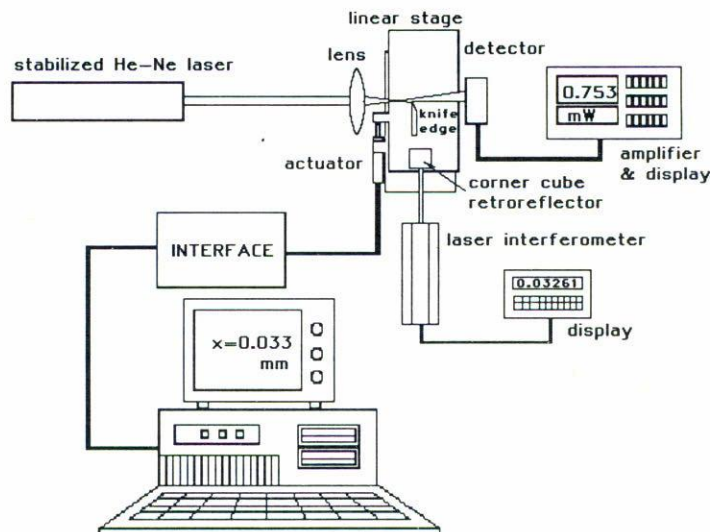

FIGURE 2. Modified experimental setup. In this case a positive lens is used for focusing the laser beam, reducing then the beam and increasing the sensitivity of the method. For this case a Laser Interferometer was used for the comparison.

TABLE II. Comparison of measured value for the relative position of the laser and the knife beam and the knife edge. Focused beam.  $P_T = 1.346$  mW;  $r_0 = 0.030$  mm;  $\Delta x_{meas}$  data given by the interferometer.

$N$	$\Delta P$ (mW)	$\Delta x_{meas}$ (mm)	$\Delta x_{cal}$ (mm)	$\delta(\Delta x)$ ( $\mu\text{m}$ )
1	0.1083	-0.00297	-0.00303	0.06
2	-0.0120	0.00031	0.00034	-0.03
3	-0.1248	0.00339	0.00349	-0.10
4	0.0600	-0.00156	-0.00167	0.11

Finally, it is well worth to state that the present method can be used for any beam whose profile does not change in time. For that case, the transmitted power profile has to be measured and, if there is not an analytic expression for describing it, a look up table has to be done, in order to relate the power variations to the relative beam-knife edge position values. Due to the fact that the transmitted power through the knife edge is always a monotonous relation, it can be reverted so that the method is usable. Caution has to be placed for the case that the beam presents zero intensity regions, as for example those of the non fundamental transversal modes of a laser beam, where a sligth motion of the beam may not produce an appreciable variation of the transmitted power if the edge of the knife is completely lying on such a region.

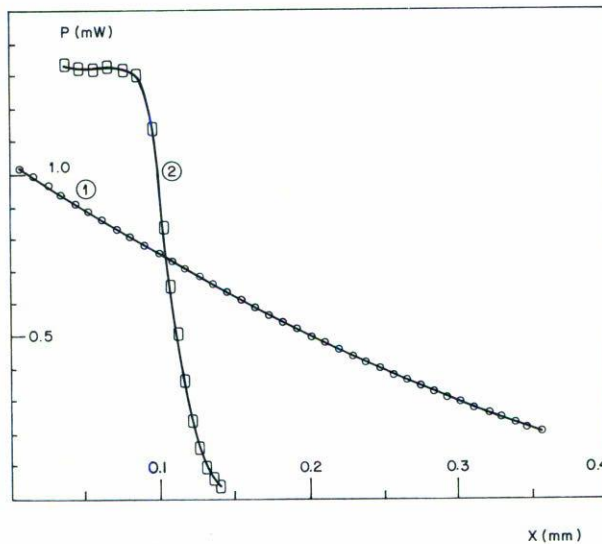

FIGURE 3. Transmitted power measured by the detector as a function of the knife edge position. Plot 1: direct beam. Plot 2: focused beam. The change in the beam radius is evident.

## 5. CONCLUSIONS

In this paper is shown that a position sensing of a He-Ne laser Gaussian beam can be accomplished with very high accuracy, by only using a knife edge and a laser power meter. The method simply consists of partially blocking out the beam with a knife edge and measuring the transmitted laser power, then by using Eqs. (5) or (6), where applicable, compute the relative position of the beam with respect of the knife edge. The method is direct and reliable. This technique can be used with unexpensive accesories and could be extended to two axis position sensing and to non Gaussian beams.

## ACKNOWLEDGEMENTS

Authors of this work are indebted to Ing. Rigoberto Nava, for his help in the use of the Laser Interferometer, and to Fermín Granados for his valuable help in the lab for doing the experiments for this work. This work was partly supported by CONACYT under grants No. P228COX880287 and A128CCOE-921363(CE-7).

## REFERENCES

1. R. Díaz Uribe, *Pruebas Ópticas por Deflectometría* (Optical Testing by Laser Beam Deflectometry), PhD Thesis, Universidad Nacional Autónoma de México, México (1990).
2. C. Cornejo Rodríguez and A. Cordero Dávila, "Measurement of radii of curvature of convex and concave surfaces using a nodal bench and He-Ne laser", in *Appl. Opt.* **19** (1980) 1743.
3. Y. Yoneda, A. Arai, and Y. Nishimoto, "Automatic surface inspection system for magnetic



- disk substrates using a laser multisensing technique", OSA Annual Meeting, 1989 Technical Digest Series, vol. 18, (Optical Society of America, Washington, DC, 1989), p. 236.
4. K.V. Kowalski, T.E. Milner, Jr., and M.J. Stanich, "Beam deflection as a method for testing optical components", in *Appl. Opt.* **25** (1986) 3735.
  5. G. Hausler, and G. Schneider, "Testing optics by experimental ray tracing with a lateral effect photodiode", *Appl. Opt.* **27** (1988) 5160.
  6. A. Cornejo Rodríguez, J. Pedraza Contreras, A. Cordero Dávila, F. Cobos Dueñas, "Measurement of the refractive-index of a lens for one wavelength (6328Å)", in *Appl. Opt.* **20** (1981) 2975.
  7. R. Díaz Uribe, A. Cornejo Rodríguez, J. Pedraza Contreras, O. Cardona-Núñez, and A. Cordero Dávila, "Profile measurement of a conic surface, using a He-Ne laser and a nodal bench", in *Appl. Opt.* **24** (1985) 2612.
  8. J.A. Arnaud, W.M. Hubbard, G.D. Mandeville, B. de la Clavière, E.A. Franke, and J.M. Franke, "Technique for fast measurements of Gaussian laser beam parameters", in *Appl. Opt.* **10** (1971) 2775.
  9. J.M. Khosroffian and B.A. Garetz, "Measurement of a Gaussian laser beam diameter through the direct inversion of knife-edge data", in *Appl. Opt.* **22** (1983) 3406.
  10. R.L. McCally, "Measurement of Gaussian beam parameters", in *Appl. Opt.* **23** (1984) 2227.