

Probe beam wave-guiding induced by spatial dark solitons in photorefractive $\text{Bi}_{12}\text{TiO}_{20}$ crystal

M.D. ITURBE CASTILLO, J.J. SÁNCHEZ-MONDRAGÓN, S.I. STEPANOV

*Instituto Nacional de Astrofísica, Óptica y Electrónica
Apartados postales 51 and 216; 72000 Puebla, Pue., México*

M.B. KLEIN AND B.A. WECHSLER

*Hughes Research Laboratories
3011 Malibu Canyon Rd. Malibu, CA 90265, USA*

Recibido el 15 de septiembre de 1994; aceptado el 16 de noviembre de 1994

ABSTRACT. Generation of two-dimensional spatial dark solitons by 180° phase jump or amplitude jump in a beam of cw HeNe laser is reported for cubic photorefractive $\text{Bi}_{12}\text{TiO}_{20}$ crystal under the application of an external electric field. Their waveguiding properties are demonstrated using another HeNe laser probe beam.

RESUMEN. Reportamos por primera vez, a nuestro conocimiento, la generación de solitones oscuros espaciales bidimensionales por medio de un salto de fase o un salto de amplitud en un haz láser continuo de HeNe. El medio no lineal utilizado fue un cristal fotorrefractivo de $\text{Bi}_{12}\text{TiO}_{20}$ sometido a un campo eléctrico externo continuo. Las propiedades de guía son demostradas utilizando como haz prueba otro láser de HeNe.

PACS: 42.50.Rh

Photorefractive crystals (PRC's) are highly promising optically nonlinear media for experiments on optical spatial soliton generation and propagation at extra-low (μW) cw laser power. Bright spatial soliton propagation was reported in different photorefractive crystals recently [1,2]. Because of the capability of easily switching the sign of the photorefractive nonlinearity by a simple inversion of the applied dc voltage, the generation of dark spatial solitons is also possible in PRC's. In this paper we report that is to our knowledge the first experimental observation of fundamental spatial dark solitons which were generated in a cubic photorefractive $\text{Bi}_{12}\text{TiO}_{20}$ (BTO) crystal.

In the present experiments we used two cw HeNe lasers of 10 mW and a $9\text{ mm} \times 5\text{ mm} \times 2\text{ mm}$ BTO crystal grown at Hughes Research Laboratories at Sta. Barbara. The output beam of the first, pump, HeNe laser was filtered and expanded up to 2 cm diameter. This pump beam was used to illuminate a mirror with a step-like profile (to have a 180° phase jump) or a thin wire (to have a rectangular intensity distribution, *i.e.*, an amplitude jump). The image of the mirror (or the wire) was imaged on to the input surface of the

*Text of the poster presentation reported at CLEO/Europe'94 (August 28–September 2, Amsterdam, The Netherlands).

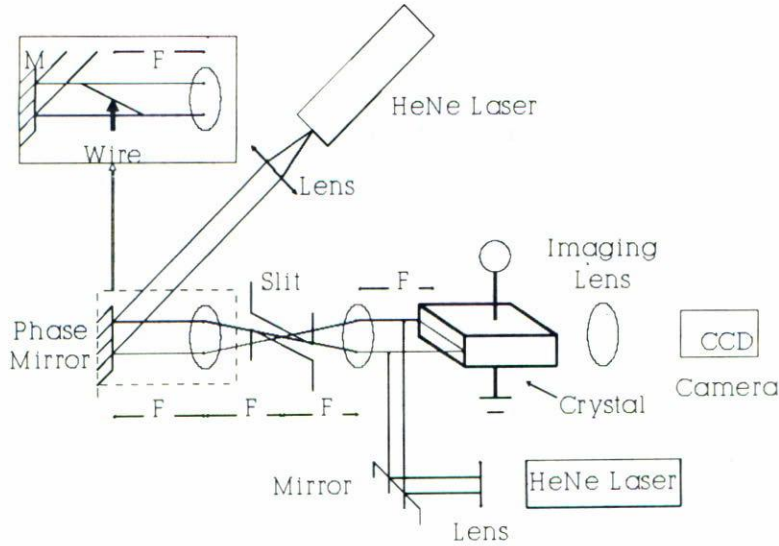

FIGURE 1. Experimental configuration for the observation of the spatial dark solitons generated by 180° phase jump and amplitude jump (see inset). M is a conventional mirror.

crystal by a standard 4F Fourier transform optical system (Fig. 1). This system allowed to change the width of the dark stripe in the middle of the pump beam via a variable width slit located in the Fourier plane of the imaging system.

The [110] cur BTO crystal was oriented with its longest size along the propagation direction of the pump beam. The external dc electric field was applied along the shortest size of the sample. To increase the efficient electrooptic coefficient of the crystal the external field and the polarization of the light (in most of the experiments) were oriented along the [111] crystallographic axes [3] (see Fig. 1).

Another HeNe laser beam (*i.e.*, the probe beam) enabled an uniform illumination of the sample interelectrode spacing via a beam splitter put in front of the crystal, both lasers beams propagated inside the sample nearly colinearly. The input and output profiles of the dark stripe in the pump beam (oriented perpendicular to the direction of application of the electric field) were measured using an additional imaging system. It consisted of an imaging lens, a slit, and a CCD camera. The slit in the focal plane of the imaging lens allowed to select the particular beam detected by the camera.

The main purpose of the uniform illumination was to control the profile and depth of the photoinduced refractive index change produced by the pump beam [2]. This probe beam was also used to demonstrate the guiding properties of the waveguide formed in the sample volume as a result of the dark soliton generation.

Two kinds of initial condition were used in the experiments. The mirror with a step-like produced a phase delay of 180° between the opposite sides of the beam. In our experimental configuration the profiled mirror created a minimum dark stripe of around $11 \mu\text{m}$ in the middle of the beam cross section. This width could be additionally increased via a slit in the Fourier plane of the system. Note that this case is known as the "odd initial condition" for spatial soliton generation [4].

In the other case when the wire was used to shade the central part of the beam (to

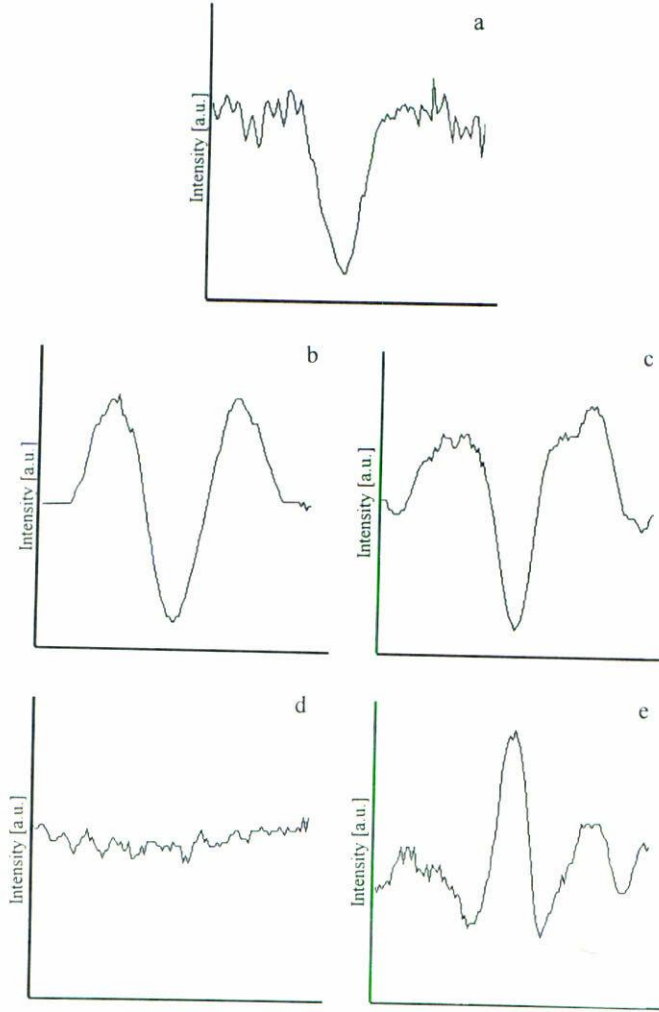

FIGURE 2. Illustration for the dark stripe propagation through the BTO sample and its wave-guiding properties with odd initial conditions (180° phase jump). Input width of the dark stripe was $23 \mu\text{m}$ and the polarization was nearly vertical: a) Pump beam input intensity distribution (at the input surface); b) pump beam output intensity distribution with no voltage applied. c) The same with 1.5 kV applied; d) output intensity distribution in the probe beam without voltage and e) the same with 1.5 kV applied.

create a dark horizontal stripe) is known as the “even condition” for spatial soliton generation [4]. Indeed, the light wave field on the two sides of the bright pump beam background, separated by the dark stripe, is in phase.

The difference between these two initial conditions for nonlinear regime of the pump beam propagation through the PRC is illustrated by Figs. 2 and 3. In the first case (with the 180° phase jump) Fig. 2a shows the initial light intensity distribution at the input face of the crystal. After propagation through the crystal this distribution was changed. Figures 2b,c show the output light intensity distribution without and with application of 1.5 kV to the sample.

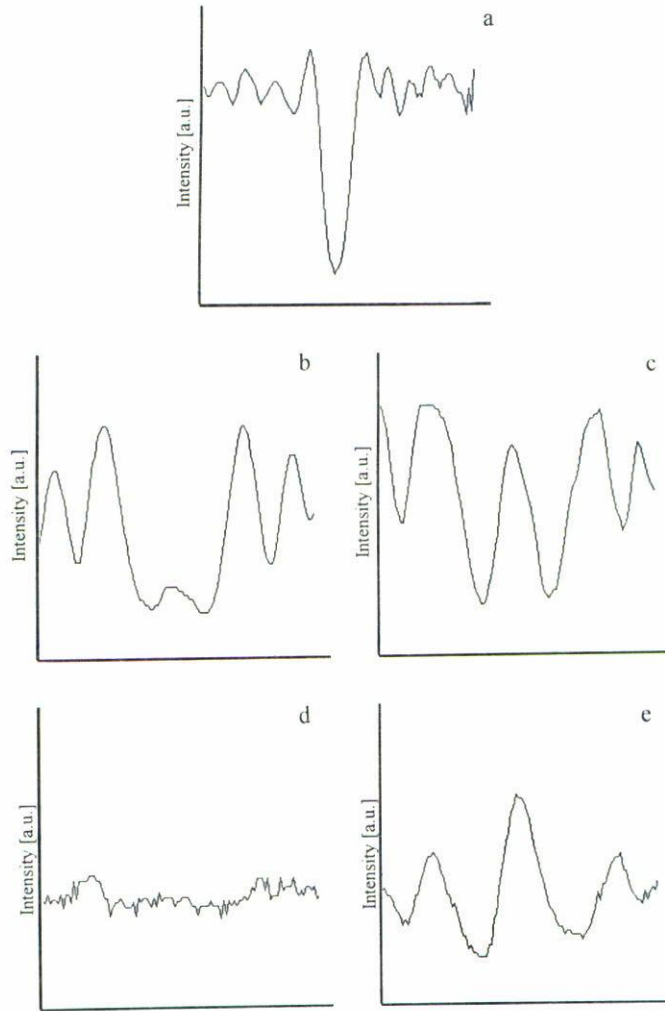

FIGURE 3. Illustration of the dark stripe propagation through the BTO sample and its waveguiding properties with an even initial conditions (amplitude jump). Input width of the dark stripe was $35 \mu\text{m}$ and its input polarization nearly vertical. a) Pump beam intensity distribution at the input surface of the sample; b) output pump beam intensity distribution with no voltage applied; c) the same with 1.5 kV applied. d) The output intensity distribution in the probe beam with no voltage applied and e) the same with 1.5 kV applied.

In its turn Fig. 3 demonstrates the experimental results obtained with the shading wire (the amplitude jump). Figure 3a shows the input intensity distribution, Fig. 3b the output distribution for linear propagation (without external voltage), and Fig. 3c illustrate the output beam profile after 1.5 kV was applied to the sample.

The former input profile (with the odd initial condition) produces a single narrowed output irradiance minimum which correspond to the fundamental spatial dark soliton generation. The even initial condition produces two irradiance minima which can be interpreted as generation of a pair of dark solitons [4]. We discuss the details of these two different experimental configurations and corresponding results below.

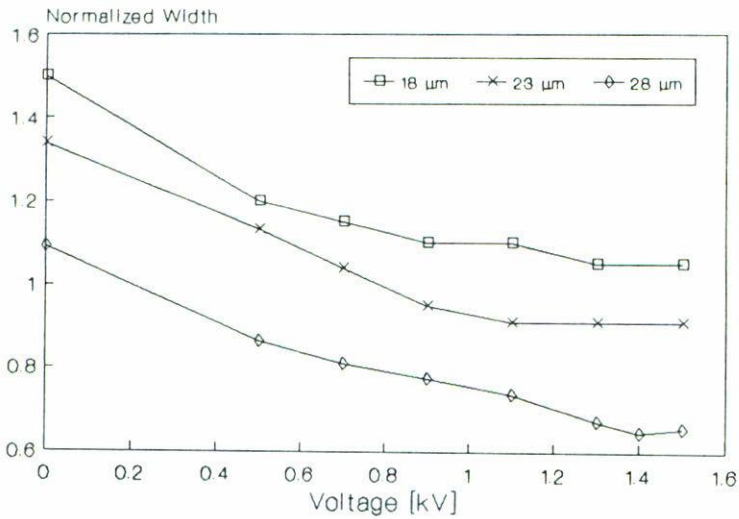

FIGURE 4. The output dark stripe width (180° phase jump) versus external voltage for different input widths of the stripe (180° phase jump): a) $18 \mu\text{m}$, b) $23 \mu\text{m}$ and c) $28 \mu\text{m}$. The output dark stripe width was normalized to the input one. The polarization of the pump beam was nearly vertical and the pump/probe beam ratio $\mu \sim 3$.

Note before this, that there are some optimal experimental parameters that must be carefully chosen for efficient photorefractive soliton generation and its following stable propagation, and in particular: 1) The initial input width of the dark stripe in the pump beam; 2) the value of the applied voltage, 3) the polarization of the incident light and 4) the intensity ratio (μ) between the intensities of the pump beam and probe (spatial uniform) beams.

1. PHASE JUMP EXPERIMENT

For the case of phase jump the dependence of the output stripe width on initial width of the dark stripe and that on external dc electric field are shown in the Fig. 4. In these experiments the stripe width was measured at 0.5 level of the average pump beam intensity. The widths of the output dark stripe were observed for the following input stripe widths: a) $18 \mu\text{m}$, b) $23 \mu\text{m}$ and c) $28 \mu\text{m}$. It is clear that for the first curve (minimum input stripe width), the initial width was never recovered after application of the maximum voltage available (1.5 kV). This means, that the value of photorefractive nonlinearity, reached for this field was not enough to support such a narrow soliton. Effect of narrowing of the output profile was observed, however, for all the voltages applied.

In the second case (Fig. 4b) the initial stripe width was recovered under application of 800 V only and further narrowing occurred for higher voltages. Finally, for the curve presented in Fig. 4c the initial width was overcome even for the minimum voltage (about 500 V) applied to the crystal. Depending on the initial width different levels of narrowing were obtained for different applied voltages. Let us stress here the fact that the recovering of the input beam width at the output crystal surface means, from our point of view, that

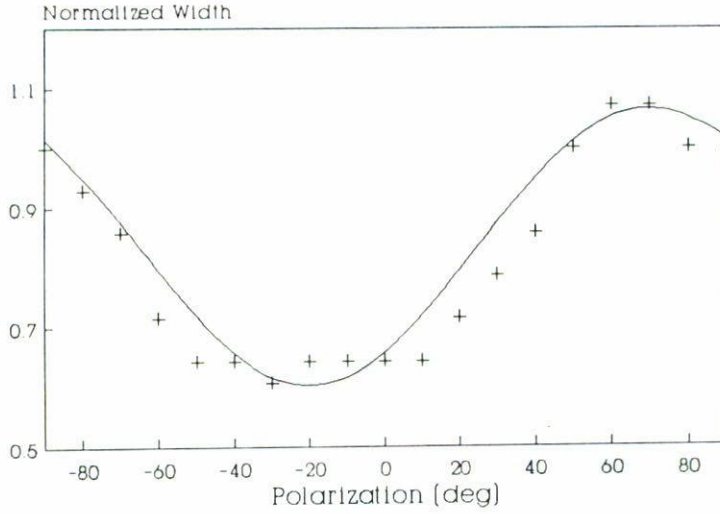

FIGURE 5. Experimental dependence of the normalized output dark stripe width (180° phase jump) on input polarization of the pump beam. Input width of the dark stripe was $23 \mu\text{m}$, applied voltage 1.5 kV, pump/probe beam ratio $\mu = 3$ and polarization was counted from the vertical axis. Continuous line represents the sinusoidal approximation.

we experimentally reached conditions of stable dark stripe propagation, *i.e.*, the stable fundamental dark soliton propagation. Dark solitons of different width needed clearly different values of photorefractive nonlinearity, *i.e.* the different external voltages applied.

The input polarization of the pump beam is another parameter that is important for observation of spatial dark solitons in photorefractive crystal. In Fig. 5, we show the experimental dependence of the output dark stripe narrowing for $23 \mu\text{m}$ width of the input stripe and maximum applied voltage of 1.5 kV. In agreement with results of [3], in this case to obtain the maximum narrowing, the optimum polarization was nearly vertical (0°). Some shift of the maximum in Fig. 5 from this optimal orientation of polarization can be attributed to natural optical activity of BTO ($\sim 6.3^\circ/\text{mm}$).

Notice that for orthogonal (horizontal) input polarization the effect of application of an external field was opposite, *i.e.*, the width of the output dark stripe grew. This also corresponds to the results on the change of the sign of photorefractive effect in this arrangement reported in Ref. [3]. In the experiments corresponding to the above Figs. 2–4 nearly vertical input polarization of the pump beam was used.

The width of the output dark stripe was also measured as a function of the intensity ratio (μ) between the two beams (pump and probe) incident on the crystal (Fig. 6). In this case the intensity of the pump beam was kept constant and the intensity of the uniform illumination was changed using two polarizers. For the beam intensity ratios μ exceeding 1 change of the output beam width is not significant, but for the intensity ratios between 1 and 0.2 there was a steep dependence of the width on μ . The input dark stripe width in these experiments was $23 \mu\text{m}$ and the optimal nearly vertical polarization of the pump beam was used.

It is well known that as a result of spatial soliton propagation (both bright and dark) some changes to the refractive index of the medium are produced in such a way that

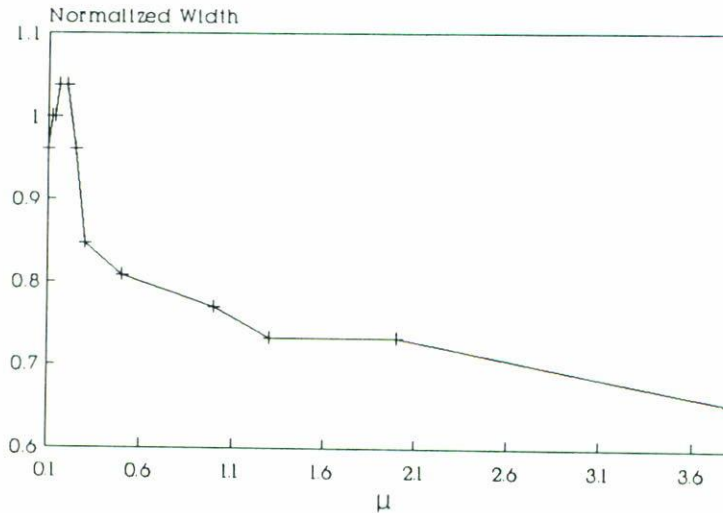

FIGURE 6. The normalized output dark stripe width (180° phase jump) as a function of the input pump/probe beam ratio μ . Input width of the stripe was $23 \mu\text{m}$. The applied voltage was 1.5 kV, polarization of the pump beam was nearly vertical.

another beam can be guided along the soliton axis. To demonstrate these effect the output intensity distributions in the probe light beam (that was used to produced the sample uniform illumination) was detected with the CCD camera in our experiments. Figures 2d and e corresponds to the cases when there was no voltage applied and when 1.5 kV was applied to the sample.

In a case of the initial 180° phase jump we generated one fundamental dark soliton. In this case the light of the probe beam must be guided along the narrow dark stripe of the pump beam. Figure 2e shows how the initial output uniform light distribution was changed after application of the voltage to give some bright and dark stripes. Position of the central bright stripe corresponds exactly to the dark one in the pump beam. Strength of the focusing depended on the value of the applied voltage and polarization of the probe beam which must also be nearly vertical for efficient waveguiding. Note that similar results on guiding along the soliton axis were also obtained using the probe beam generated by a semiconductor laser with different wavelength (750 nm) [5].

2. AMPLITUDE JUMP EXPERIMENTS

For the case of the input amplitude jump there was a remarkable growth of the output intensity in the center of the dark stripe instead of narrowing of its width which was discussed above for the phase jump. This structure of the output beam profile allows to say that in this case we excite a pair of the antiphase dark solitons which is typical for the amplitude jump (*i.e.*, even initial conditions) [4].

The pump beam parameters for observations of the efficient soliton generation with this initial conditions were basically the same as those for the above case except for the initial input width of the dark stripe. Figure 7 shows dependence of the intensity

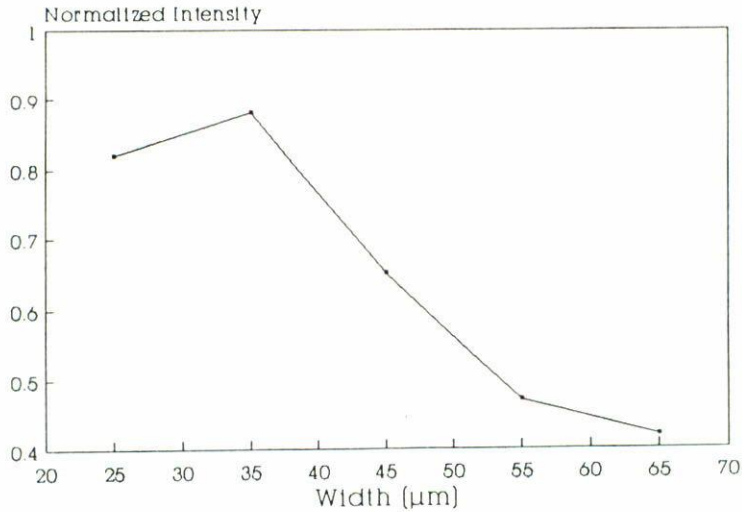

FIGURE 7. The output intensity of the central bright stripe (even initial conditions-amplitude jump) versus width of the input dark stripe. The applied voltage was 1.5 kV, polarization of the pump beam nearly vertical and $\mu = 1$.

of the central (growing) bright stripe on the input stripe width for the applied voltage of 1.5 kV. The intensity of this bright stripe was normalized to the uniform background level of the pump beam. Note that for the input widths bigger than $35 \mu\text{m}$ we observed even a decrease in the initial intensity of the central stripe. For this input width the dark stripe after propagation through the sample was practically not influenced by the external voltage applied.

Using the optimum input stripe width found in the above experiment we measured dependence of the central bright stripe intensity on the voltage applied (Fig. 8). Note that even without applied voltage the central area of the amplitude jump at the output of the sample was not completely dark due to normal linear diffraction after propagation through the sample thickness. When the voltage was applied the intensity of this central bright stripe was increased and probably for the voltages a little higher than 1.5 kV it could be possible to reach the intensity of the pump beam background.

Influence of the pump beam polarization on the intensity of the central bright stripe for the applied voltage of 1.5 kV is shown in Fig. 9. As for the phase jump case, nearly vertical polarization proved to be optimal here as well.

The waveguiding properties of this soliton structure generated by the amplitude jump were also investigated. Figures 3d and 3e show the light distributions in the output probe beam profile when there was no applied voltage and with 1.5 kV applied, respectively. In this case it is not possible to say that the probe light was guided precisely along two dark stripes distinguished in the output pump beam. The difference observed can probably be associated with some difference of the output phase in the bright central stripe of the pump beam from the theoretically predicted 180° . In fact, this phase shift measured interferometrically proved to be less than this value.

Summarizing we report the first experimental evidence of two-dimensional dark spa-

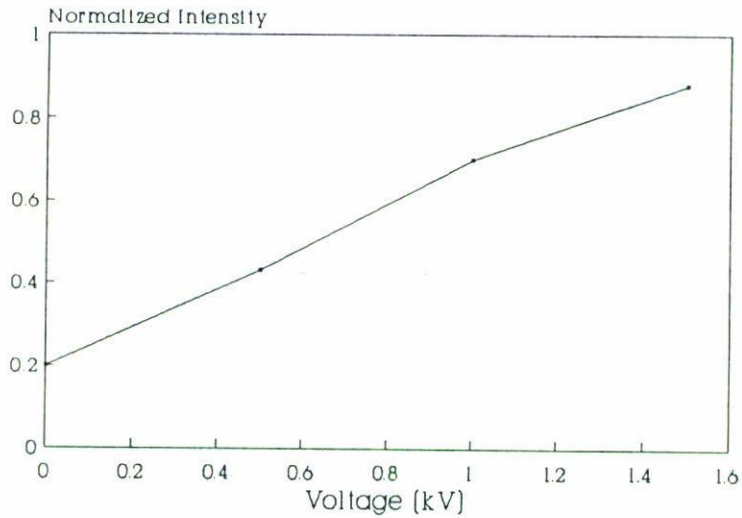

FIGURE 8. The output intensity of the central bright stripe (even initial conditions amplitude jump) versus applied voltage. The input width of the dark stripe was $35 \mu\text{m}$, polarization of the pump beam vertical and $\mu = 1$.

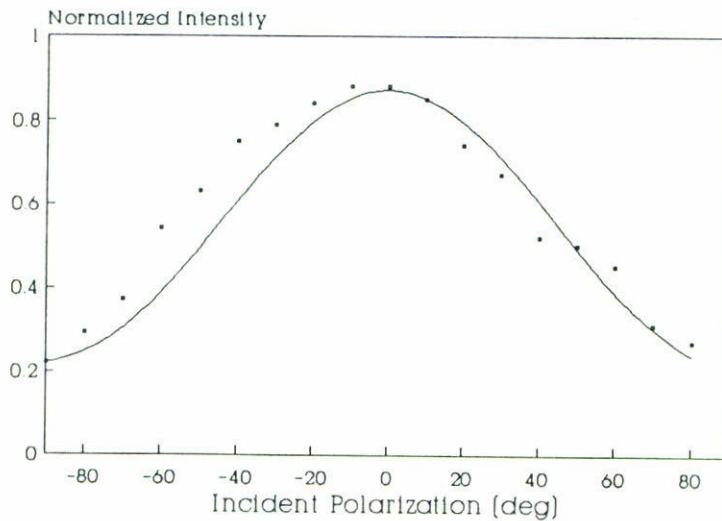

FIGURE 9. Experimental dependence of the intensity of the central bright stripe (even initial conditions amplitude jump) on the polarization of the pump beam. The applied voltage was 1.5 kV, input width of the dark stripe was $35 \mu\text{m}$, polarization of the pump beam vertical and $\mu = 1$.

tial soliton propagation in photorefractive crystal under application of the external dc electric field. Spatial solitons were generated in cubic photorefractive $\text{Bi}_{12}\text{TiO}_{20}$ crystal by phase and amplitude jumps in the cw HeNe laser pump beam as initial (odd and even) conditions. Odd initial condition resulted in one fundamental dark spatial soliton generation. Even initial condition produced a pair of antiphase dark spatial solitons. Optimal experimental conditions (in particular), width of the input dark stripe and the

light polarization) for efficient dark soliton generation in $\text{Bi}_{12}\text{TiO}_{20}$ crystal were obtained. The guiding properties of the photorefractive spatial dark solitons were also demonstrated using additional He-Ne cw probe laser beam.

ACKNOWLEDGEMENTS

The authors would like to express their sincere gratitude to A. Torres from Electronic Department of INAOE for preparation of the profiled mirror.

REFERENCES

1. G.C. Duree, J.L. Shultz, G.J. Salamo, M. Segev, A. Yariv, B. Crosignani, P. DiPorto, E.J. Sharp, and R.R. Neurgaonkar, *Phys. Rev. Lett* **71** (1993) 533.
2. M.D. Iturbe Castillo, P.A. Márquez Aguilar, J.J. Sánchez-Mondragón, S. Stepanov, and V. Vysloukh, *Appl. Phys. Lett.* **64** (1994) 484.
3. S.I. Stepanov, S.M. Shandarov, and N.D. Khat'kov, *Sov. Phys. Sol. State* **29** (1987) 1754.
4. Y. Kivshar, *IEEE Jour. Quan. Electron.* **29** (1993) 250.
5. M.D. Iturbe Castillo, P.A. Márquez Aguilar, J.J. Sánchez-Mondragón, S.I. Stepanov, M.B. Klein, and B.A. Wechsler, "Probe beam wave-guiding induced by spatial dark solitons in photorefractive $\text{Bi}_{12}\text{TiO}_{20}$ crystal" in *Conference on Lasers and Electro Optics* 1994, Optical Society of America, Technical Digest Series Vol. 15, p. 236.