

## Some considerations regarding the exit pupil location in some visual systems

V.M. Durán-Ramírez and D. Malacara-Doblado  
*Centro de Investigaciones en Óptica, A.C.,  
 Apartado Postal 1-948, 37000 León, Gto., México*  
*e-mail: vicdur@cio.mx*

J.M. López Ramírez  
*Instituto Tecnológico y de Estudios Superiores de Monterrey, Campus León*  
*Apartado Postal 872-1, 37190 León, Gto., México*  
*e-mail: juan.manuel.lopez@itesm.mx*

Recibido el 21 de octubre de 2003; aceptado el 20 de enero de 2004

The proper location of the eye with respect to a visual optical instruments is not a trivial problem. It depends on many practical factors not widely known. This paper describes some of the many factors that determine the best position for the pupil of the observer with respect to the optical system which is not necessarily the exit pupil of the system. The practical consequences of this problem are very important for the design of visual systems.

*Keywords:* Optical system design.

La localización apropiada del ojo con respecto a un instrumento óptico visual no es un problema trivial. Depende de muchos factores prácticos no conocidos ampliamente. Este artículo describe algunos de los muchos factores que determinan la mejor posición para la pupila del observador con respecto al sistema óptico el cual no es necesariamente la pupila de salida del sistema. Las consecuencias prácticas de este problema son muy importantes para el diseño de sistemas visuales.

*Descriptor:* Diseño de sistemas ópticos.

PACS: 42.15.Eq

### 1. Introduction

The final image in a visual instrument is formed at the retina of a human eye. If the eye is emetropic, that is, if it does not have any refractive error, the virtual image provided by the instrument has to be located at an infinite distance [1]. The coupling of the visual instrument to the eye is done by locating the eye close to the exit pupil of the instrument. The distance from the last optical surface of the system to the exit pupil is called the *eye relief*. It is frequently assumed in most lens design textbooks [2] that the exit pupil of a visual optical system has to be located at the entrance pupil of the observing eye.

It has been pointed out that the selection of the proper position for the eye is quite important in binocular head mounted displays [3,4], since this position may affect the estimated depth of the observed object [3,4]. However, this is not the only consideration to be made regarding the exit pupil position as described here. Many other factors have to be considered.

### 2. Some considerations regarding the ideal observer's pupil position

It is a little known fact that the best position for the pupil of the observer with respect to the optical system is not always the exit pupil of the system. The optimum pupil location has several solutions depending on several factors and circumstances. The practical consequences on the selection of its location are very important for the design of visual systems.

When designing visual instruments we may encounter two different situations:

- a) The exit pupil is a real image of the system stop, located at the exit of the optical system. In many instruments, like in Keplerian telescopes and periscopes the stop is at the entrance pupil of the system, which is the aperture of the first lens in the system. In these cases the exit pupil position and its diameter are well defined.
- b) In some other systems, like in ophthalmic lenses, magnifiers and Galilean telescopes with a large objective diameter (See Fig. 1), the stop and the exit pupil position of the system are at the pupil of the observing eye. Since the eye rotates in its socket to observe off-axis points, the stop of the system frequently has move off-axis. So, an effective position to consider for the stop is at the center of rotation of the eye globe. In these systems the exit pupil of the system is located wherever the center of rotation of the observer's eye globe is placed. This position will be called the apparent stop. Our justification for this is that at the apparent stop all off-axis principal rays cross the size of the apparent stop is about the same as the size of the pupil of the eye divided by the cosine of the angle of the peripheral vision.

Now let us study these two types of visual systems with some more detail.

**2.1. Systems with a Fixed and Accessible Exit Pupil**

It is well known that the eye relief in eyepieces of visual instruments [5,6] with a fixed position for the exit pupil should measure at least 10 mm to provide enough space for the eyelashes. An eye relief of 15 mm provides a more comfortable viewing or even 20 mm is necessary for people wearing eyeglasses. For raffle sights the eye relief should be at least 60 mm to give space for the raffle recoil. Usually, a large eye relief requires a large diameter for the eyepiece lens.

In these systems where the exit pupil is determined by a physical stop in the system, which is not the pupil of the eye, it is commonly stated that the pupil of the observing eye should be at the exit pupil of the instrument. Walker [7] points out that when an observer looks to an object at the center of the field as in Fig. 2(a), and then moves the eye globe to look to another object at the edge of the field the pupil is automatically decentered as in Fig. 2(b). Then, the object at the edge of the field is clearly seen, but much dimmer due to a vignetting effect that has been quantitatively analyzed in detail by Rosete-Aguilar and Rayces [8]. Its magnitude depends on the field angular size as well as on the diameter of the exit pupil and the pupil of the eye.

Thus, this position for the observing eye with respect to the exit pupil is correct if the objects of interest are small and in the vicinity of the optical axis. A typical example is a visual astronomical telescope. However, if the objects of interest are located at many points over a wide field, the vignetting appears.

This vignetting can be avoided if the head is slightly moved laterally to center again the exit pupil of the system with the pupil of the eye. The observer does this adjustment to correct this decentering [7] in an instinctive manner.

An alternative way to avoid this vignetting is by selecting another location for the exit pupil, at the center of the eye globe, but this arrangement also has some problems. It is clearly shown in Fig. 2(c), that in this case the pupil of the eye has to be larger than the exit pupil of the visual system. If the vignetting is to be avoided, the diameter  $D_e$  of the pupil of the eye should be at least

$$D_e \geq D_s + 2C \tan \Theta \tag{1}$$

where  $D_s$  is the diameter of the exit pupil, and  $C$  is the semi-diameter of the eye globe, generally consider to be 14 mm for an emmetropic eye.

In this case the eyepiece design becomes more complicated because the eye lens also increases greatly its diameter.

When looking at an object at the center of the field all the objects at any position within the field will have the same apparent brightness. However, if an object at the edge of the field is directly observed as in Fig. 2(d), and the exit pupil of the system is smaller than the pupil of the eye, then the objects located on the opposite side of the optical axis of the object of interest will be much dimmer or even invisible.

If the exit pupil of the optical system is much smaller than the pupil of the eye the vignetting effects are small and

thus the tolerance in the position of the eye along the optical axis is much greater. An example of this kind of system is a wide field microscope or an indirect ophthalmoscope. Ideally, the eye relief should be large enough to be able to place the center of rotation of the eye at the exit pupil of the system. However, this condition tends to increase the necessary diameter of the eye lens too much. Then, an intermediate solution is advisable as a compromise, as clearly pointed out by Rosete-Aguilar and Rayces [8].

**2.2. Systems where the stop is the pupil of the eye**

The second case of optical system is when the stop of the system is the pupil of the observing eye, that is, that the optical

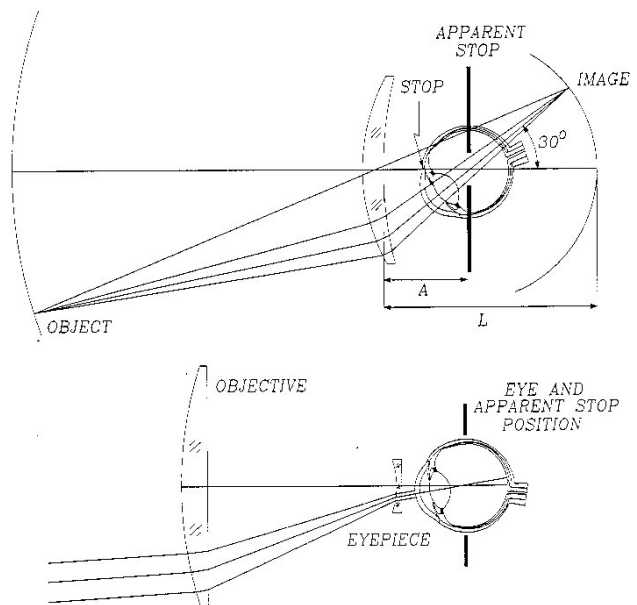

FIGURE 1. Exit pupil in an ophthalmic lens and a Keplerian telescope.

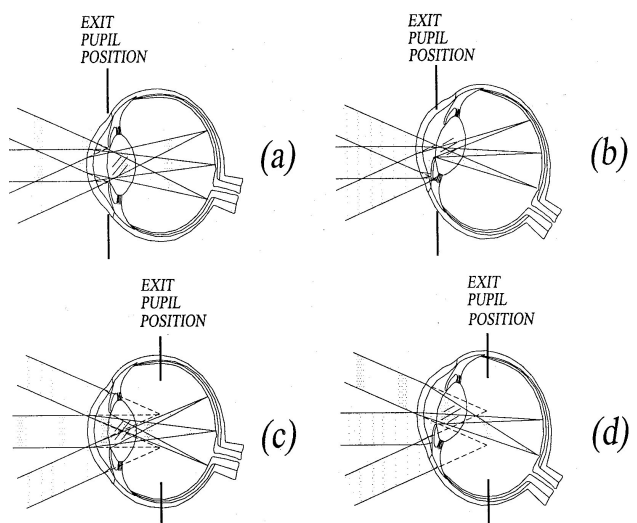

FIGURE 2. Illustration of the blocking of the light by the pupil of the eye for two different locations of the observing eye.

system has not an exit pupil or stop when the eye is removed, as in ophthalmic lenses, magnifiers or systems with a wide field as illustrated in Fig. 1. The exit pupil is the pupil of the eye, but it is a movable stop that moves with the eye. When designing this kind of systems the evaluation of the quality of the image has to be made with the stop at a different off-axis position for each off-axis viewing direction. In this case it is better to consider a fixed stop located at the center of rotation of the eye.

In these systems the vignetting effects do not appear. However, when designing these systems one of the two following situations have to be considered:

- a) The objects of greater interest are always near the center of the field. Peripheral objects are never directly observed, but their presence is important. For example, when wearing eyeglasses we read by slowly moving our head to keep the letters at the optical axis. Peripheral objects, that is, off-axis objects without any rotation of the eye should be clearly imaged, mainly for security reasons. In this case the exit pupil should be considered at the pupil of the eye. This case has recently been studied [9].
- b) The objects of interest are distributed over the whole field of view and the instrument can not be constantly and fast moved to center at the optical axis of the observed object. A typical example is a galilean telescope observing a screen with text. Ideally, the telescope should be fixed and only the eyes should move. Another example are eyeglasses to be used for fast reading a wide field text. Then, the practical situation is a fixed observers head with his eyes moving fast. In these cases when designing, the exit pupil can be considered to be at the center of rotation of the eye as we are always correcting the foveal imaging.

In Fig. 3(a) the off-axis beam produces an extra foveal image. When the eye rotates the off axis beam may not enter the eye, as illustrated in Fig. 3(b), unless the eye is laterally shifted as in Fig. 3(c), then, the off-axis beam produces a foveal image. The optical system can be designed to produce the best possible off-axis image, either when the eye is not rotated as in Fig. 3(a), or when the eye is rotated as in Fig. 3(b). In the first case we speak of peripheral non-foveal imaging and in the second case of peripheral foveal imaging. An optical system like this, can not be optimized for both situations. The designer has to select either one by placing the exit pupil either at the pupil of the eye or at the center of rotation of the eye globe. The selection depends on the relative importance that the lens designer gives to peripheral vision, according to the intended application. In neither of these two cases there is any vignetting.

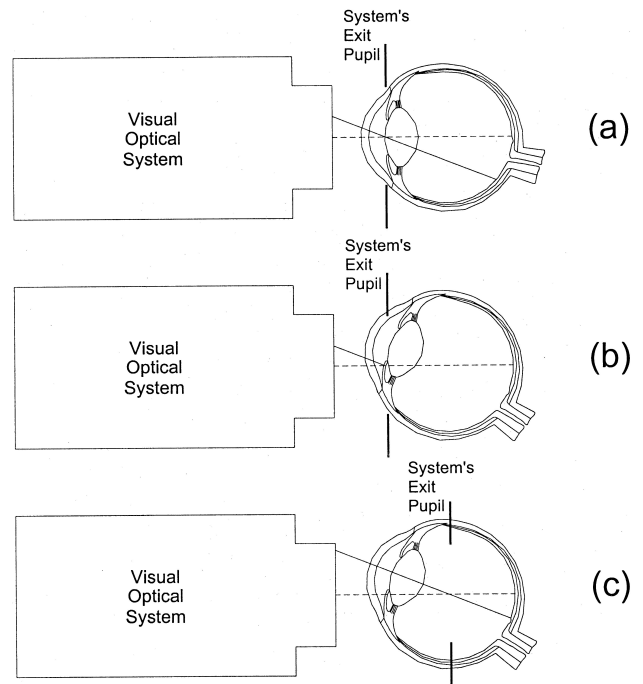

FIGURE 3. Observing on-axis and off-axis objects in a visual optical systems.

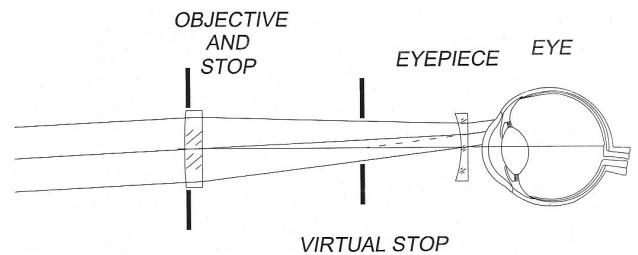

FIGURE 4. A Galilean Telescope with a virtual exit pupil.

### 2.3. Systems with a fixed and unaccessible exit pupil

Some instruments have a stop and hence an exit pupil located inside the systems in a non accessible place. That is to say, it is a virtual image of the stop. An example of this kind of system is a Galilean telescope with a relatively small objective diameter, as illustrated in Fig. 4. In these cases vignetting is unavoidable and there is not an ideal location for the eye. The best we can do here is to place the eye as close as possible to the eyepiece.

## 3. Conclusions

We have described some of the possibilities for the best selection of the location of the eye in visual optical systems. There is not a unique well defined position but several ones can be applied to visual systems depending on its configuration and application. In conclusion, the best position for the eye has not a simple solution and care should be taken when performing the optical design.

## Acknowledgments

The authors wish to acknowledge the very valuable comments by Dr. Martha Rosete and several other colleagues dur-

ing the development of the work. V.M. Durán Ramirez wish to thank to the Consejo Nacional de Ciencia y Tecnología for its financial support.

- 
1. E. Hecht, *Óptica* (Addison Wesley Iberoamericana, Madrid, 2000) p. 218.
  2. F.G. Smith and J.H. Thompson, *Óptica* (Limusa, Mexico, 1979) p. 173.
  3. L. Vaissie, J.P. Rolland, and G.M. Bochenek, "Analysis of eye-point locations and accuracy of rendered depth in binocular head-mounted displays", in Conference on Stereoscopic Displays and Applications X, *Proc. SPIE* **3639** (1999) 57.
  4. L. Vaissie and J.P. Rolland, "Accuracy of rendered depth in head-mounted displays: role of eyepoints location", in Helmet and Head-Mounted Displays V, *Proc. SPIE* **4021** (2000) 343.
  5. R.E. Hopkins, Eyepieces, in *Military Standardization Handbook: Optical Design, MIL-HDBK 141* (U.S. Defense Supply Agency, Washington D.C., 1962).
  6. M. Laikin, *Lens Design*, M. Dekker (New York, 1991) p. 101.
  7. B.H. Walker, *Optical Design for Visual Systems* (SPIE Press, Bellingham, Washington, 2000).
  8. M. Rosete-Aguilar and J.L. Rayces, *Applied Optics* **41** (2002) 6593.
  9. G. Smith, D.A. Atchison, C. Avudainayagam, and K. Avudainayagam, *J. Opt. Soc. Am. A* **19** (2002) 10.